

Ringling in multi-party telephone lines

Douglas A. Kerr

Issue 4
January 10, 2025

ABSTRACT AND INTRODUCTION

A multi-party telephone line (often called just a “party line”) uses a single pair of conductors (today usually in a cable) from the telephone central office to serve two or more subscribers. The motive is to spread the capital and maintenance cost of the cable pair, and of the equipment associated with it at the central office, over two or more subscribers’ service, allowing for lower rates than for an *individual line* (a single-party line, often called by the general public a “private line”).

A major issue in the implementation of this principle is how to alert (“ring”) a specific party when an incoming call is for that party. Many different schemes emerged over the years, and several eventually came into widespread use.

This article discusses these multi-party line ringing systems.

1 BACKGROUND

1.1 A matter of terminology

I note that in official Bell System publications, “multi-party” is used only to refer, as a class, to lines having more than 4 parties (perhaps 8, 10 or 20). But here I will continue to use “multi-party” to mean any line with more than one party.

1.2 Tip and ring notation

Under manual telephone switching, the connections between parties were made by human operators at switchboards. The connections were made by coupling and control circuits (*cord circuits*) whose two ends terminated in cords with plugs. These plugs were inserted into jacks in the switchboard that led to the telephone lines.

In general, the plugs had three contacts (and of course the jacks had mating contacts for all three).



Figure 1. 310-type switchboard plug

Figure 1 shows a typical switchboard plug.

The three contacts I referred to above are referred to as the *tip*, *ring*, and *sleeve*, rather obvious choices. The *dead ring* is not a contact; its purpose is to provide a substantial (and durable) gap between the tip and ring contacts so that they cannot be momentarily bridged (“short circuited”) by the ring contact spring in the jack as the plug is inserted.

The tip and ring contacts carry the path to the conductors of the telephone line itself. The sleeve contact carries a lead that is used only for various control purposes inside the switchboard.

Because of this history, even today, in the U.S., regardless of the type of switching equipment (if any), the two conductors of the telephone line (or any telephone circuit) are normally called the *tip* and *ring* conductors. I will use that terminology in this article.

1.3 Battery

In both manual switchboards and automatic (“dial”) switching systems, the DC voltage from which the system operates is supplied by a system of large storage batteries that are continually recharged by rectifier systems (or earlier, motor-generators)—essentially the same scheme used on automobiles. As a result, in describing the operation of telephone circuits, the DC voltage is often spoken of as “battery”.

For an esoteric but important reason (which I will not describe here), in most cases the “battery” voltage was negative with respect to ground (thus my mention, for example, of “-48 V”).

1.4 The basic ringing signal

In a basic individual telephone line, the called subscriber is alerted by applying to the line (at the central office) a *ringing signal*, which consists of:

- an AC component with relatively high voltage (perhaps 90 V RMS) and a relatively low frequency (often 20 Hz), plus
- a DC component, often at -48 V.

This is often called “superimposed ringing”, as a DC component is “superimposed” on the basic AC signal. But as we will see later, in practice, that term is usually reserved for a specific application of the concept.

The AC component of this signal operates the ringer (which a civilian would call the “bell”) at the called telephone station, giving an audible signal to announce that there is an incoming call.

Normally the ringing signal is applied as a containing series of “bursts”, a common pattern (or *cadence*) being 2 seconds of ringing followed by 4 seconds of no ringing (the *silent interval*). During the silent interval, -48 V is applied to the line. The purpose of the DC component of the ringing signal proper, and the DC during the silent interval, will be seen later.

1.5 The ringer

The ringer is a key player in many of the scenarios I will discuss here, so I thought it best to first give some insight into this creature.

Until about 1950, most telephone ringers were fairly-obvious refinements of a basic design devised by Thomas Watson (yes, the famous assistant of Alexander Graham Bell) in about 1879.

1.5.1 *The Western Electric B-type ringer*

Figure 2 shows an important example of that line of development, the Western Electric B-type ringer developed by Bell Telephone Laboratories, Inc., for use in the 300-series of telephone sets, introduced in 1937. This specimen is from 1940.

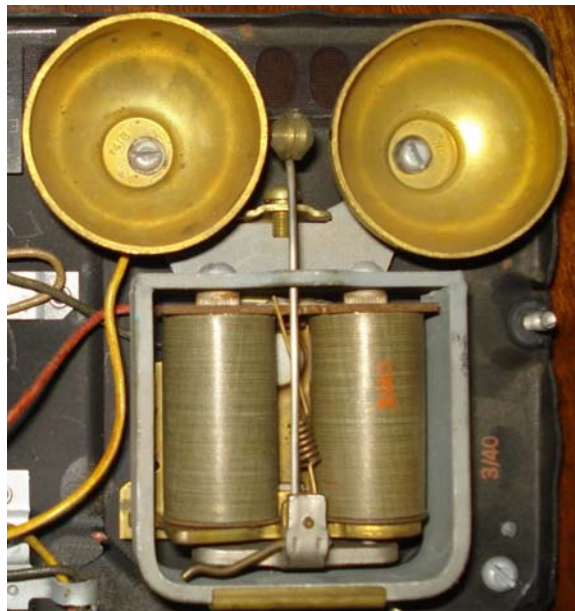

Figure 2. Western Electric B-type ringer

The ringer includes the *motor*, which comprises an *electromagnet*, a *permanent magnet*, and a pivoting *armature*. The AC component of the ringing signal arriving at the station is fed, by way of a capacitor, through the coils of the electromagnet, causing the armature to move back and forth. The armature carries a *clapper rod* with a *clapper* at its end. The motion of the armature makes the clapper move back and forth, alternately striking the two *gongs*. The two gongs resonate at different frequencies (normally a musical major third apart), thus giving the iconic sound.

In the figure we see the electromagnet (actually comprising two coils, but I will subsequently speak of “the coil”, or even just “the ringer”) and the permanent magnet (the gray box-like structure surrounding the coils).

We might think we see here a squared-off version of the iconic “horseshoe” magnet configuration, with one pole at each end of the horseshoe. But in fact here one pole of the magnet is across the whole top (the welded-on piece) and the other is across the whole bottom. In effect, the left and right legs are magnets in parallel.

The pivoted armature is beneath the two coils, and the clapper rod, clapper, and gongs are self-evident.

We also see a small spring, its bottom end fastened to the armature, with its top end trapped in a notch on the phenolic plate (brownish) that forms the top “spool ends” for the two coils. This is called the *bias spring*.

Its purpose is to make the armature, when there is no current flowing in the coil, lie in a certain one of its extreme positions. Otherwise, when there is no current in the coil, the working of the magnetic field of the permanent magnet would make the armature equally happy to lie firmly in either of its extreme positions (lying against the pole tip of one or the other legs of the electromagnet).

The oddly-curved bar we see extending from the armature to the left is a *stroke limiting arm*. When it is desired to reduce the loudness of the ringer, the arm can be bent so that it will strike the bottom “pole plate”, thus limiting the stroke of the armature. (In its “factory” position, as we see here, it does not affect the stroke.) Then the gong that is struck when the armature goes to that position is adjusted to be closer to the clapper arm (the gongs are mounted on off-center holes to allow their positions to be adjusted). The shorter stroke of the clapper results both gongs not being struck as forcefully.

1.5.2 Later developments

Later developments in electromechanical ringers followed significantly different physical design principles, but still followed the principles of behavior we saw above

And of course in modern times, the electronic ringer came into prominence. Here, the ringing voltage pulses were rectified and used to power an oscillator connected to a small "loudspeaker", which made a unique audible sound.

2 THE INDIVIDUAL TELEPHONE LINE

2.1 Introduction

For the moment, I will speak of individual line (not multi-party) telephone service.

For each line, a pair of conductors (today almost always in a cable) goes from the serving central office to the subscriber's location. At the central office, there is some circuitry distinctly associated with the line. In electromechanical offices, this is often a *line circuit*, which primarily comprises a relay used to determine when the subscriber has "lifted the handset" to place a call.

When the line is idle, a DC voltage (typically -48 V in modern central offices) is applied to the line. At the station, with the handset "on hook", there is no DC continuity so no current flows through the line.

2.2 The basic telephone set circuit

For reference in the discussions to follow, Figure 3 shows the basic conceptual circuit of a telephone set (as would be used on an individual line).¹

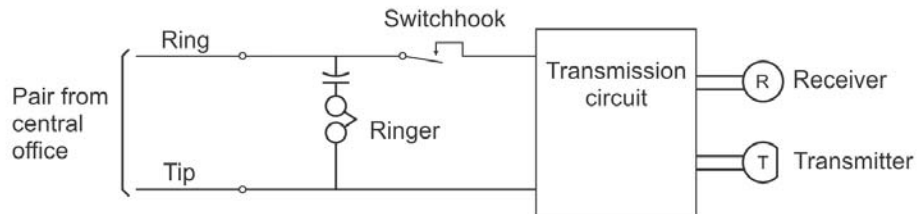

Figure 3. Basic telephone set circuit (individual line station)

¹ The figure omits various details not pertinent to the story here, such as the dial (if any), contacts to mute the receiver while the dial contact or the switchhook line contact is opening or closing, and so forth.

The transmission circuit comprises a transformer, capacitors, resistors, and so forth. It is used to couple the receiver and transmitter to the line. It does this in such a way that the voice signals from the transmitter do not come back into the receiver at “full strength” (an arrangement called an “anti-sidetone” circuit, *sidetone* referring to the speaker’s voice coming out of his own receiver, a phenomenon that is good but only if it is not “too strong”).

Note that there is DC continuity through the transmission circuit.

The switchhook contact is operated by plungers or such in the handset cradle. When the handset is in the cradle, the contact is open, and there is no path through the transmission circuit (the *on hook* state of the telephone set). When the handset is lifted (the off hook state of the set), the contact is closed, and the path is completed (the *off hook* state of the set).

We see that the ringer (that is, its coil)² is connected, though a capacitor, from the ring conductor to the tip conductor. The capacitor provides that there is no “DC continuity” through the ringer circuit. Thus with the set on-hook, no (DC) current will flow through the line, even though there is voltage across the line.

2.3 Initiating (“originating”) a call

When the subscriber lifts the handset (“goes off-hook”), the switchhook contact closes, completing the path to the transmission circuit (which has DC continuity), and thus current flows in the line. A *line relay* (or equivalent) associated with the line at the central office detects this current, and the switching system makes the necessary preparations for the subscriber to make a call, including sending dial tone over the line (this assumes the use of automatic, or “dial”, switching, but for manual switching the functions are wholly analogous).

Generally speaking, the DC current that flows when the telephone set is off hook serves to energize the *transmitter* (microphone) at the set, which traditionally is of a variable-resistance type (what would be called in a different context a “carbon microphone”).³

² I use here the “traditional” schematic symbol for the ringer. This is derived from the construction of ringers for many years. They had two cylindrical coils on metal cores, side by side (much as we see in figure 2). The two coils were connected in series, this being done at first by small “pigtailed” from one end of each coil being soldered together “in the open”. The little “V” on the symbol is evocative of that joint.

³ In modern telephone sets, the transmitter may be of the moving-coil or electret type, requiring an amplifier to increase its output signal to that required to send over

2.4 Receiving a call

Notifying the subscriber that there is an incoming call is done by sending the ringing signal (described above) over the line. This signal is “applied” from one line conductor to the other.

However, one side of the source of the ringing signal is at ground potential. It is this side that is connected to the tip conductor, which thus ends up at ground potential.

At the telephone set, the ringer coil is connected, in series with a capacitor, across the two line conductors. The capacitor prevents any DC current from flowing through the ringer. When the line is idle such current flow would be misinterpreted as a request to make a call, and during a call, any flow of DC current through the ringer would take away from the current available to energize the transmitter. But the reactance of the capacitor at 20 Hz is low enough that the AC component of the ringing signal will pass to the ringer, causing it to ring.

As mentioned earlier, there is a DC component to the ringing signal (usually -48 V) and, during the “silent intervals” in the ringing pattern, a DC voltage (again usually -48 V) is applied to the line. The ringing voltage/silent interval voltage is applied at the central office through the coil of a relay⁴ that will only respond to a DC component of the current through it, not to any AC component. This is referred to as the *ringing trip relay*.

With the telephone set idle (as it should be if an incoming call is being directed to it), there is no DC continuity through it. Thus there is no DC component to the *current* that flows in the line from the ringing signal (in either its “ringing” or “silent interval” phases), even though there is a DC component to the *voltage* during both phases.

But as soon as the subscriber lifts the handset, there is a DC path through the transmission circuit of the telephone set, and thus there is a DC component to the current that flows in the line from the ringing signal (in either phase).

This DC current operates the ringing trip relay (or triggers its electronic equivalent). This causes the central office equipment to remove the ringing signal and complete the path for the transmission of voice over the connection, a process called *ringing tripping* (hence the name of the relay).

the line In that case, it is that amplifier that is normally powered by the DC current that flows in the line.

⁴ In modern central offices this is actually replaced by an electronic circuit.

3 THE CONCEPT OF THE MULTI-PARTY LINE

The basic concept of a multi-party telephone line (usually called by the general public a "party line") is that a single pair of line conductors will provide service to two or more subscribers (the "parties" actually referred to in the name). In technical discussions, their telephone *stations* (telephone sets, for all practical purposes) are often referred to as the "parties" on the line. But here, for the sake of rigor, I will mostly use the term "station" for the station.

The stations of the various parties are connected in parallel to the line conductors.

The objective is to share the cost of the telephone line conductors themselves, and as well the direct and indirect cost of the supporting equipment for the line at the central office, over several subscribers' service.

This in turn allows for a lower rate for "party line" (e.g., multi-party) service than for "individual line" (single-party) service (often called by the general public a "private line"^{5 6}).

In reality, a single pair may not be shared by all the parties for the whole distance from the central office. It typically is in a rural situation, where the telephone cable (or perhaps even an open wire line) runs along a road on which all the parties live. As the cable passes each subscriber, a service wire ("drop wire") is connected to that pair and leads to the house.

But in an urban or suburban neighborhood, the multiple parties might not live on the same street. There, the single pair coming from the central office might, in a neighborhood *cross-connecting cabinet*, be connected (in parallel) to pairs in two or more cables that run down different streets.

It should be noted that in a multi-party line (as usually implemented in the U.S. and Canada), when one party is using the line, any other party, if they pick up the handset at their station, will hear what is being said, certainly a gap in "privacy". In fact, the way they must find out if the line is already in use is to pick up the handset. If there line is busy, they will probably hear the existing conversation, and in

⁵ That term formally has a much different meaning: a telephone line that is not part of the switched telephone network.

⁶ When I was growing up, in a suburb of Cleveland, Ohio, two-party service was the norm for middle-class residential subscribers. If one of the gang had a "private line", we considered him to be "sort of rich".

any case will not get dial tone. And they may be anxious to place a call, "right now".

There is of course a gigantic body of "etiquette", "ethical" and even "legal" issues involved here! (Such matters are beyond the scope of this article.)

The use of multi-party lines has waxed and waned over the history of the telephone industry.

But in more recent times, the telephone companies moved away from offering this kind of service (other than perhaps in rural areas), and by the 1970s (in the U.S.), regulatory and policy developments and the ensuing practical considerations, together with economic and market shifts, brought nearly its complete demise as to general use other than in rural areas.

4 SIGNALING THE CALLED PARTY

4.1 Introduction

A major technical issue is how, upon the arrival of a call for one of the parties on a multi-party line, does the central office signal ("ring") that parties station. There are numerous schemes, the important ones of which I will describe.

4.2 Divided ringing

This was the usual implementation for two-party lines, which were very common in the Bell Telephone system in urban and suburban areas. Here, at each station, the ringer is connected not from tip to ring but rather from ring (or tip) to ground, which of those being determined by which party that station is.

At the central office, to ring the first party station, the ringing signal is applied to the ring conductor (against ground, of course; it always really is) with the tip conductor grounded. The ringer at that station is connected from ring to ground, and thus is activated, The ringer at the other station, connected from tip to ground, receives no voltage and is not activated.

Figure 4 shows the ringer circuit arrangement at the first party station (often called the "ring party", because of the side of the line on which its ringing signal is sent).

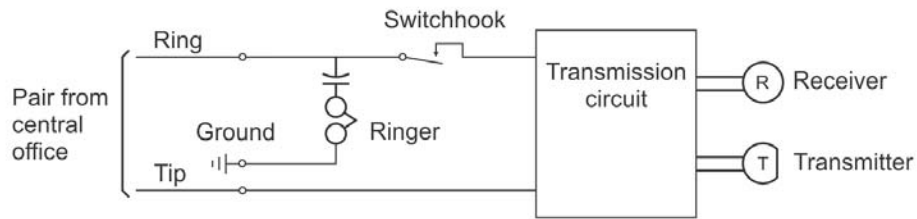

Figure 4. Ringer circuit at ring-party station

Note that this application of voltage by the central office is in fact exactly what is done to ring an individual line (even though we think of it here in a different way).

To ring the second party's ("tip party") station, the ringing signal is applied to the tip conductor (against ground, of course), with the ring conductor grounded. The ringer at that party is connected from tip to ground, and thus is activated by that signal. Figure 5 shows the circuit arrangement at the tip party.

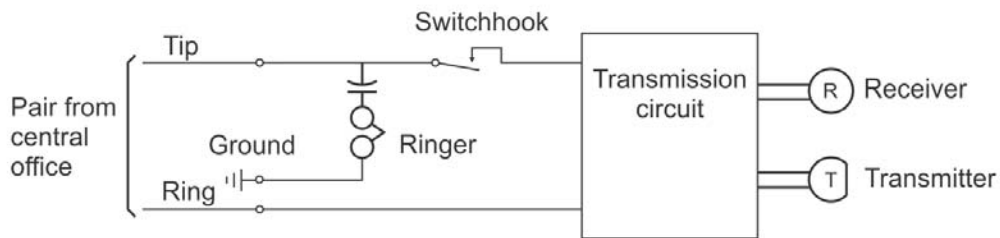

Figure 5. Ringer circuit at tip-party station

We note that this station is wired just like the ring party station, except that the tip and ring conductors are reversed. This is in fact the way this difference is usually actually implemented at the tip party station, reversing the two line conductors in the telephone set cord, versus the two conductors of the inside wiring, at the connecting block (typically found on the baseboard).

When this station is rung, the ringer at the other station, connected from ring to ground, receives no voltage and is not activated. Thus this is a *full-selective* system: when one party is rung, the other party hears no ringing.

Note that for this system we must have at the station a reliable "local" ground, normally obtained from a nearby metal water pipe, or a ground rod driven into the earth if a metal water pipe is not available. (You have perhaps seen the little yellow tags on the ground wire at the station "protector" warning us not to disturb it.)

4.3 Four-party semi-selective ringing

This was used occasionally in the Bell Telephone System to offer four-party line service in urban and suburban areas.

In this system, two of the party stations have their ringers connected to the ring conductor and the other two to the tip conductor (as we saw before for divided ringing).

Of the two stations whose ringers are connected to one side of the line, for one the ringing signal has a “one ring” cadence and for the other party it has a “two ring” cadence.

Thus at each location, ringing is heard both for call to that party and for calls to one other party, but not for the other two parties. This is thus characterized as a “semi-selective” ringing system.

This ringing system can be technically called a “divided code” ringing system (“code” referring to the different ringing cadences), but that term is not usually applied here.

4.4 Four-party full-selective ringing

This was widely used by the Bell Telephone System for four-party lines in urban and suburban areas. Four electrically-unique ringing signals were used, distinguished by combinations of two two-fold properties.

- The ringing voltage is applied to the **ring** or **tip** conductor of the line (as we saw before for divided ringing).
- The DC component of the ringing signal is either **positive** or **negative**. (It is always negative for the basic ringing systems we saw before.)

In figure 6, we see illustrations of the ringing signal waveform for both positive and negative DC components:

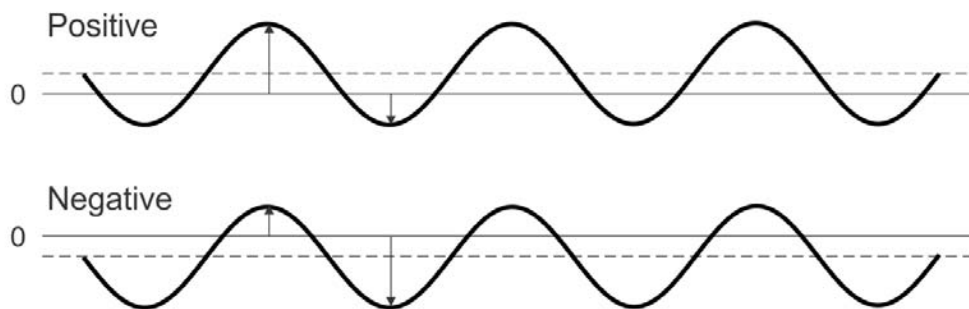

Figure 6. Superimposed ringing waveforms

Note that with the positive DC component, the positive excursion of the voltage (with respect to zero) is substantially greater in magnitude than the negative excursion. With the negative DC component, the opposite is true. As we will see later, this is a pivotal distinction.

The ringer is essentially identical to that used for individual line and two-party line applications.

At two of the stations the ringer is connected from ring to ground; at the other two stations, from tip to ground. For the two stations on one side of the line, two different ringing waveforms ("polarities") are used.

The discrimination between the two polarities of the ringing signal is made by the ringers themselves, which are of the familiar type (exactly the ones used for individual lines or two-party lines).

If we were to, "on the test bench", apply to the ringer coil itself the two different ringing signals, one would cause the ringer to respond and the other would not. (Do not for the moment be concerned with exactly how that happens—we will see that in a "real case" a little later.)

And of course if we were to reverse the connections to the ringer coil, the ringer would now respond to the signal it did not respond to in the first test, and vice versa.

Thus it would seem that we have the tools to implement polarity-sensitive ringing control. But there is a fly in the ointment.

For the reasons I mentioned earlier, we cannot connect the ringer coil directly to the line—this would lead to the flow of DC currents we do not want.

In the ringing systems already described, we solve that problem simply by putting a capacitor in series with the ringer. But we cannot do that here. If we did, the DC component of the ringing signal would be lost, and with it the asymmetry that allows the ringer to distinguish the two ringing signals based on the polarity of their DC component..

Instead, we must have some sort of "switch" that, with the line idle (or in the talking condition) disconnects the ringer coil from the line, only connecting it when there is ringing on the line. Several implementations of this concept have been used over the years.

I will describe the one that was most widely used in the Bell system for many years. It uses a cold-cathode gas triode as that "switch". Figure 7 shows the concept.

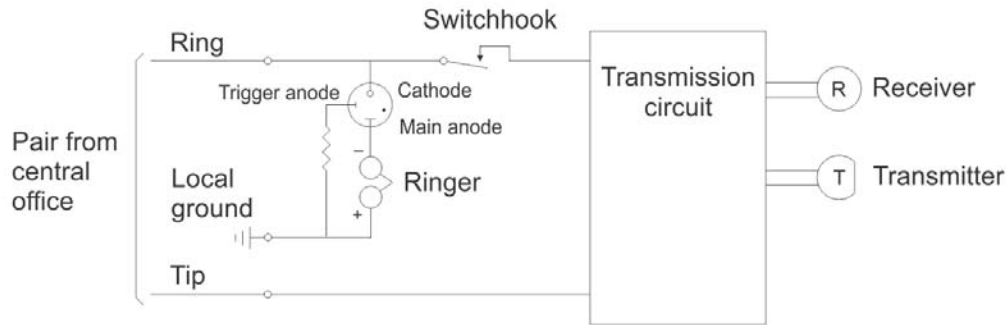

Figure 7. Four party full selective ringing with gas tube (ring/negative party)

This shows the setup for the party with ringing on the ring conductor and a negative DC component to the ringing voltage.

With the line idle or in a talking condition, the voltage on the relevant conductor of the line is never greater (in magnitude) than 48 V or so, at which voltage the trigger gap of the tube (cathode to trigger anode) does not ionize and become conductive. The main gap (cathode to main anode) similarly does not ionize and become conductive. Thus, in those conditions, there can be no flow of current through the ringer coil.

However, when any ringing signal is applied, regardless of the polarity of the DC component, the voltage during much of the cycle is great enough that the gas in the trigger gap will ionize.

(The resistor we see limits the current through the trigger gap after it ionizes.)

The ionization of the trigger gap in turn provokes the adjacent main gap to also ionize and conduct, but that will actually only happen if the main gap polarity is relatively positive on the anode compared to the cathode. (That is, the main gap operates as a rectifier once “provoked”.)

The next step of the story is illustrated on Figure 8.

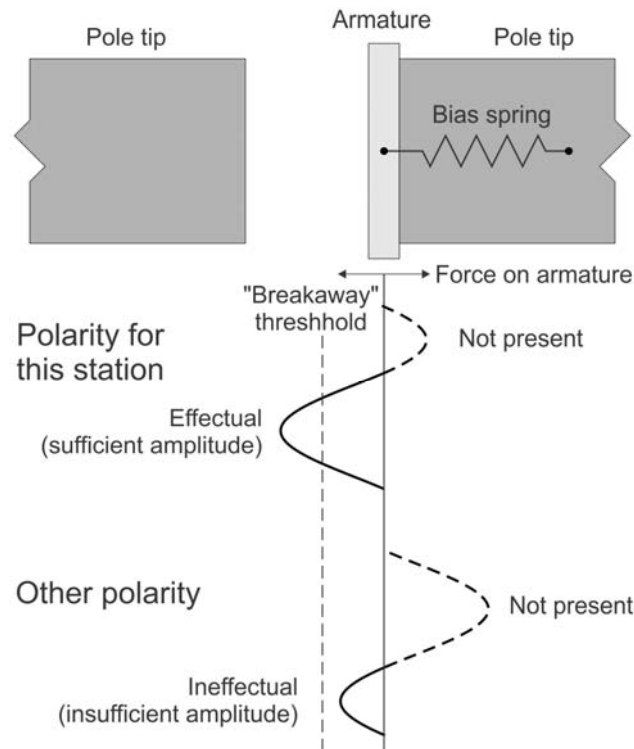

Figure 8. Force waveforms in a "gas tube" station.

The armature is shown in its resting position, forced by the bias spring.

Since the main gap of the gas tube only conducts (if it does) during one half cycle, the ringer actually receives only pulses of one polarity. The connection between the gas tube and the ringer is always such that this is always the polarity of current that will try to cause the armature to move from its "rest" position⁷.

The solid curves (for the two polarities of ringing voltage this station might receive) show the force on the armature for a full cycle of the ringing signal. The dashed line curves do not represent forces that actually occur, but would occur except for the "rectifier" effect of the gas tube. (Their purpose is only to help visualize the action in terms of the entire cycle of the received ringing signal.)

To actually move the armature, the force created in that direction must overcome the sum of (a) the magnetic effect that makes the armature want to stay against whichever pole tip it is now on and (b) the opposing force of the bias spring. That "breakaway threshold" of force is shown by the dashed line.

⁷ The ringer in Figure 7 is marked with polarity markings that show what polarity that would need to be.

If the ringing signal is the one not intended for this station (as shown by the lower curve in the figure), those pulses are of a relatively low magnitude (because of the asymmetry of the waveform⁸), and do not produce enough force to do that. Thus the armature does not move from its rest position, and the ringer doesn't sound.

If the ringing signal is the one intended for this station (as shown by the upper curve in the figure), those pulses are of a relatively high magnitude, and will cause the armature to move from its rest position to the other position (giving a "ding"). When that half cycle ends, the bias spring moves the armature back to its "rest" position ("dong").

Thus we see that the ringer will only actually respond when the ringing signal has the intended polarity of its DC component.

In a four-party line, two of the stations have the ringer connected to the ring conductor and the other two to the tip. Among the two stations whose ringers are connected to one side of the line, at one station the gas tube and ringer are wired "one way up", and at the other station, "the other way up".

Thus a ringing signal which is applied to one side of the line and has a certain polarity of its DC component will only cause the ringer at one party's station to ring.

This then is a full-selective system: when one party is rung, the other parties hear no ringing.

In some contexts, this ringing system is called "superimposed ringing", alluding to the use of a DC component as well as an AC component in the ringing signal.

Of course, the ringing used on individual lines is equally *superimposed ringing*, so the use of that term to distinguish this system case is not really apt. This usage probably comes from the far greater attention paid, in connection with this particular ringing system, to the DC component of the ringing signal.

4.5 Eight-party semi-selective ringing

Here, two of the eight stations are equipped to respond to each of the four electrically-unique ringing signals (as described for the four-party full selective system in Section 4.4), and on top of that, one- and two-ring cadences are used. Thus any party would hear ringing only for calls for them and for one of the other parties.

⁸ And in fact the voltage drop across the main gap of the gas tube actually "accentuates" that difference.

4.6 Code ringing

This system was widely used for rural multi-party lines, often with as many as 10 parties.

Here, conventional ringers are used at all stations, connected in the conventional way (from tip to ring) as seen in Figure 3. For each station there is a distinctive ringing pattern (sometimes called a “cadence”). For example, there may be, in each cycle of the cadence:

- A single ring (“normal” duration)
- Two short rings
- Three short rings
- One long ring and one short ring
- One long ring and two short rings
- Etc.

Of course, this means that for every incoming call, every party hears the ringing. (This is thus characterized as a “nonselective” ringing system) But this was a “small price to pay” for the ability to have economical telephone service (or telephone service at all, since in many places, multi-party service—with code ringing—was the only service available).

“That’s my ring” was a frequent outcry when a subscriber realized that a call was in fact for him; it became a catch phrase for other situations.

4.7 Divided code ringing

We actually heard of this concept earlier, in the four-party (semi-selective) context, but it was often used for lines with greater numbers of parties. Here, half of the stations have their ringers connected from ring to ground, and the others from tip to ground. To further distinguish among the parties with their ringers on one side of the line or the other, different ringing patterns are used (as described above under “code ringing”).

This is a “semi-selective” system in that when one party is rung, the other party whose ringers is connected to the same side of the line hears ringing, but the other two parties don’t. Thus the degree of disturbance to parties from calls to other parties is reduced, compared to the use of basic code ringing.

The term “divided code” ringing was often applied to this system when there were more than four parties involved. A common

application was for a 10-party line, where five ringing cadences (“codes”) were used.

4.8 Frequency selective ringing

4.8.1 *The Scheme*

Here, different frequencies (in the overall range of 16 Hz to 66 Hz) are used to ring the different stations. The ringers are of a special type, mechanically-resonant (see section 4.8.2), each one “tuned” to respond to only one of the frequencies in the set being used.

Figure 4 shows three different frequency systems that were used.

System	Frequencies (Hz)					Original plan
Harmonic	16- ² / ₃	25*	33- ¹ / ₃	50	66- ² / ₃	Multiples of 16 ² / ₃ Hz
Decimonic	20	30	40	50	60	Multiples of 10 Hz
Synchromonic	16*	30	42	54	66	Odd multiples of 6 Hz

- Added later; not in the “plan”

Figure 9. Frequency-selective ringing system frequencies

In the basic system, the ringers are connected (in series with a capacitor, in the usual fashion) from tip to ring. (See however below under “divided frequency selective ringing”, section 4.9.)

This is a “full-selective” system: when one party is rung, the other parties hear no ringing.

The “harmonic” plan was the first one used. Typically the different frequencies were generated by individual alternators, with different numbers of poles, driven by a common motor.

The “Decimonic” plan took advantage of the fact that these frequencies could all be conveniently generated from a 60 Hz supply by frequency division and multiplication in passive ferroresonant frequency divider circuitry.

The claimed advantage of the Synchromonic system was that, since none of the frequencies were integral multiples of any of the others, it averted a problem sometimes encountered in which flaws in the line (bad joints, etc.) caused nonlinearities, which in turn could cause the generation of harmonics from a ringing signal, which, if included in the frequency series, could inappropriately activate the ringer at another station (perhaps feebly, not much comfort to the afflicted subscriber).

The frequency selective approach was only rarely used in the Bell Telephone System, but was popular with non-Bell companies, especially for service in rural areas.

4.8.2 *Frequency selective ringers*

Frequency selective ringers prior to the 1950s usually used an overall construction similar to that we see in figure 2, with a few important exceptions:

- The armature is not mounted on a pivot but rather on a flat spring. When there is no current through the coil, the spring holds the armature in mid-stroke. The stiffness of the spring might vary depending on the frequency for which the ringer was intended to operate, but possibly being the same for more than one of those frequencies. There is no bias spring.
- The clapper itself is cylindrical, and varies in length (and thus mass) for different frequencies. The stiffness of the mounting spring combined with the mass of the clapper determines the frequency at which the armature-clapper assembly would resonate. Usually the position of the clapper along its arm is adjustable, providing a way to adjust the resonant frequency to the exact value intended.
- The stroke of the armature is limited so it never gets near enough to a coil pole piece that it would “stick” to it because of the magnetic attraction.



Figure 10. Automatic Electric Company frequency selective ringer

Figure 10 shows a typical such ringer, this made by Automatic Electric Company, for years a major supplier of telephone sets and central

office equipment to the non-Bell System world. This one is responsive to a 30 Hz ringing signal.

At the very bottom we see the armature suspension spring, a flat torsion spring. The thin toothed wheel we see above it provides for adjusting the vertical position of the armature to get the proper gap with the coil pole pieces.

We note the setscrew holding the clapper on its arm so that its position can be adjusted in order to adjust the resonant frequency of the ringer to the exact value intended.

In contrast to such a *frequency selective ringer*, the "basic" kind of ringer I have discussed before is called a *straight line ringer*.

4.9 Divided frequency selective ringing

This system uses one of the sets of five multiple frequencies (as described in section 4.8, but beyond that applies the voltage on one line conductor or the other, allowing up to 10 parties on a full-selective basis.

5 OTHER CONSIDERATIONS

There are numerous other considerations in this field, which I have not discussed in this article in the interest of conciseness. They include:

- How are telephone numbers assigned to the stations on a multi-party line?
- How does the central office apply the proper ringing signal for a call to a certain number (both for manual switchboards and for various types of "dial" switching systems)?
- On a call originated on a multi-party line, how does the central office know which station was placing the call, so that if there was a charge for the call it would be lodged against the proper party?
- How might the ringing circuit at a station conspire with spurious voltages that might be induced into the telephone line to produce "noise" on the connection, and how do we avert this?

These issues, and many others, are described in (often excruciating) detail in the much-longer companion paper, "Multi-party telephone lines", by the same author, probably available where you got this article.