

Manual Telephone Switching

Douglas A. Kerr

Issue 8
December 29, 2024

ABSTRACT AND INTRODUCTION

In the U.S., until about 1920, telephone switching was done with switchboards operated by human operators, an arrangement called *manual switching*. In the forthcoming years, this arrangement was progressively superseded by *automatic switching*, in which the subscribers used a dial to tell a *switching machine* the number they wanted to reach.

By 1960, the preponderance of U.S. telephone service was on an automatic ("dial") basis, but some manual switchboards continued in use well beyond that. (The last Bell Telephone System manual switchboard in the state of New Jersey was retired in the mid 1960s. I had the privilege of attending its dismantlement.)

It is tempting to think that the manual telephone switching system was "primitive", but it was far from that. There was enormously detailed, clever, and precise work done at the system engineering, circuit design, equipment design, manufacture and installation, and operational protocol standpoints.

In this article, I try to give the reader some idea of the basic (and some not-so-basic) concepts of the sphere of manual telephone switching, and in the process, perhaps give some idea of what a wondrous creature it was.

1 INTRODUCTION

1.1 Approach of the article

The sphere of manual telephone switching is enormously broad, deep, and complex. There are many kinds of switchboards, occupying different roles in the overall telephone network, and as well differing because of such matters as vast differences in the size of the switchboard installation in different locations. And of course there have been many changes in the details over the years.

To allow us to deal with this enormity, I will discuss each basic matter by using simplified examples so that the principle are not obscured by the rich environment of details and variations. Then I will bore a bit deeper into some of the areas, in some cases into the actual electrical circuits involved (in simplified form, though).

1.2 Context

Although the overall principles of manual telephone switching are the same worldwide, there are important differences in major details between U.S. practice and that of other countries, and with regard to U.S. practice, some notable differences in details between the practices of the Bell Telephone System and of non-Bell companies.

Unless I mention otherwise, the discussions here pertain to the U.S. and are focused on the practice of the Bell Telephone system, with switchboards manufactured by Western Electric Company, Inc.

2 HISTORICAL BACKGROUND

2.1 "Intercom" service

Telephones were initially mostly used in pairs, in what we would today call "intercom" service. A ranch owner might buy a pair from Sears, Roebuck, and Company and put one in the ranch house and another in the bunkhouse, connected by a length of baling wire strung on wooden posts. Or the operator of a large feed store might put one in the front office and another in the shipping department, at the back of the block-long building.

2.2 Telephone exchange service

But soon, in some small town, some entrepreneur (or perhaps a "cooperative" of a few of the residents) would establish what we would today call "telephone exchange service". Telephones would be installed in the various business and some of the homes, all connected by wires (often supported in part on the buildings they passed) to a central switching facility. This revolved around some type of manually-operated switchboard. There were various types used in the early days, but the type that emerged as most prominent was the cord switchboard (the progenitor of what I will describe at length in this article). The whole enterprise (and thus the switchboard) became known as a "telephone exchange".

That small switchboard might have been located in a back room of the general store. But as these systems grew, and substantial switchboards were needed to handle to traffic and number of lines, these came to be located in purpose-built (or repurposed) buildings, which came to be known as *central offices* (although civilians would often think of them as "telephone exchanges").

2.3 Telephone numbers

In many case, at first the different subscribers to the telephone exchange service were just identified by name. When Charlie signaled the operator, she might say. "Mornin' Charlie. What can I do for you?". Charlie might say, "Mornin', Clarice. Gimme the feed store."

But eventually, especially as the system grew, the subscribers were given numbers (which fit in with how the switchboard was organized). In a small system, with less than 100 subscribers, these numbers perhaps had at most only two digits. And they were not provided with leading zeros. Thus the mayor might be 2, and Charlie was 26.

2.4 As the system grew

Of course as a city really grew, it became most effective to establish more than one central office across the city, with the switchboards at the various central offices joined by *trunk circuits* (just "trunks" for short). For one thing, this minimized the total number of "conductor-miles" of telephone wires needed to connect all the subscribers in the city to a central office.

And so, to describe a wanted line to the operator, one needed to give both the "name" of the central office that served it¹ and its "station number". Perhaps the original central office came to be known as "Main" (how's that for original), while the newer one on the west side of the city was perhaps named "West" (or maybe "Lakeview", if that was what that neighborhood was generally called).

So a caller, wanting to call the infamous Charlie, might tell the operator that took her call, "Main 26, please."

3 A FIRST LOOK

Just to give some insight into the full glory (or horror) of manual switchboards, in figure 1 we see a large one of many years ago. I'll comment on some things seen in the picture as we go along.

¹ Civilians understandably often thought of these as "exchange names", but in fact "exchange" eventually came to have a quite different leaning: A region (such as the "Cleveland Exchange") within which there was a certain uniform service rate policy and within which (usually, but not always) calls were not "long distance".



From an original glass negative,
restored by Roy Blair²

**Figure 1. Manual telephone switchboard
(Salt Lake City, Utah, installed 1907)**

4 TECHNICAL ODDS AND ENDS

4.1 Magneto and common-battery systems

As I mentioned earlier, at first, telephones were most often used in pairs in an “intercom” setting. For the most part, the earliest telephone sets used a hand-cranked generator (often called a “magneto”³) to generate a low frequency (perhaps 15-25 Hz), fairly high voltage

² Thanks to Alexis Kasperavičius of Berlin who, in 2021, did extensive research to identify this photograph and eventually a contemporary newspaper article discussing its installation.

³ Its construction, of which the most visible part was a set of several horseshoe magnets, seemed to parallel the magnetos used for ignition in auto (and even airplane) engines.

(perhaps 65-90 V RMS) AC signal that operated the ringer (“bell”) of the telephone set at the other end of the line.

As such telephones became stations in a telephone exchange system, working through a manual switchboard, that same signal was used to alert the operator that a user wanted to make a call. Then of course a similar signal, sent from the switchboard (sometimes even from a hand-cranked generator) went to the called⁴ party to ring the ringer there and alert them that they had an incoming call.

The DC energy to activate the transmitter (“microphone”) of the telephone set (these were of the variable resistance variety) came from dry-cell batteries (usually with the large cells that eventually came to be called “number 6 dry cells”) located in the telephone set or a nearby housing.

A major advance in telephone operation used DC current sent over the line (from the switchboard) to activate the transmitter. This was of course desirable in that it eliminated the need for the telephone company to periodically replace the batteries at all the stations.⁵ An additional advantage was that the telephone set could, with a switch, control whether or not current would flow through the telephone set and the line.

Thus to make a call, the user lifted the receiver (the “earpiece”) from the hook on which it was hung when the telephone was not in use. The hook rose under the influence of a spring, which closed a switch, allowing current to flow in the line from the DC source at the switchboard, which (typically by operating a relay that energized a lamp) alerted the operator that the particular user wished to place a call.⁶

This came to be known as *central energy* operation, which gradually changed to *central battery* operation, and finally to *common battery* operation.

Then, in contrast, the earlier arrangement came to be called *local battery* operation. But, because of the type of signaling almost invariably used in that arrangement, it is also often spoken of as

⁴ Pronounced in two syllables.

⁵ As the telephone industry formed, the telephone companies for the most part insisted on supplying, owning, and controlling the telephone sets, but with that came the obligation to feed them batteries, rather a pain, actually.

⁶ Alerting the station of an incoming call was done with essentially the same type of low-frequency AC signal used in “magneto” operation.

magneto operation (especially in describing switchboards operating on that basis).

Indeed, as you can well imagine, ordinarily different kinds of switchboards were used for magneto and common-battery operation⁷ (although there were switchboards that could accommodate lines of both types).

In this article, we will consider solely common-battery operation.

4.2 Multi-party lines

In a multi-party line (known to the general public as a “party line”), a single pair of wires leads from the switchboard to two or more subscriber stations.⁸ This of course has economic benefits through the sharing of the cost of the single pair of wires (and as well what we would today call the line’s “port” at the switchboard).

There were several different schemes of operation of multi-party lines, and two substantially-different principles of their operation at a switchboard, all with wonderful details and great cleverness of engineering and design.

In the body of this article, I will limit the discussion to the “individual” (single-party) line. In Appendix A, I will discuss two very common multi-party systems and their implementation in a manual switchboard. That appendix also gives references to two companion articles giving much more detail on this complex topic.

4.3 Central offices and switchboards

Simplistically, a telephone *central office* is a facility that provides telephone exchange service in some region of a city. The term implies both the building and its equipment.

Under manual switching, a *switchboard* is the item that actually (under the care of its operators) switches the calls at a central office.

In discussing call handling in a city that has more than one central office (each of course with its own switchboard), for a call to a subscriber served by a different central office than that of the caller, I may speak broadly at first of the call being extended to another

⁷ It might seem curious that the distinction was not “local battery” vs. “common battery”, but there was a subtle technical reason for that (I won’t discuss it here).

⁸ The pair may have parallel branches as we near the neighborhood of the stations, for example if they are on separate streets.

central office, but then, getting more into the details, speak of its arriving at the *switchboard* there.

Another aspect of this matter is discussed in section 15.

5 TIMELINE

It is beyond the scope of this article to present a detailed historical timeline for the development and evolution of manual switching systems.

But is it useful to note that the cord-based manual switchboard of the type discussed here has essentially reached “adulthood” by the year 1900. By that I mean that as of that time the overall design, in terms of physical construction, circuit concepts, and method of operation, had stabilized.

Of course there were continual refinements and improvements made on many fronts over the decades. Nevertheless, if we examined a “mainstream” Western Electric manual switchboards made in 1900 and 1930, we would be hard pressed at first glance to note the differences.

6 MANUAL SWITCHBOARD CONSTRUCTION

6.1 “A” and “B” local switchboards

By *local switchboard* I mean switchboards that are not involved in the switching of long distance calls in the “interior” of the long distance network. They may be involved in the “terminal” aspects of long distance calls (that is, the interface of the two telephone subscribers to the long distance connection), although that will not be discussed in this article.

In the most common architecture of manual telephone switching, in cities having more than one central office, there are two types of local switchboards. Each central office will be equipped with one of each type. These are called “A” and “B” switchboards.

In the basic scheme, an “A” switchboard’s operator:

- Answers a subscriber’s request to originate a call.
- Completes the call if it is to another line served by the same switchboard (the same central office).
- In a city with more than one central office, for a call to a line served by another central office, advances the call over a *trunk circuit* (“trunk”) to that central office.

A "B" switchboard's operator:

- Attends to a call, destined for a line served by its office, coming into the office over a trunk from the "A" switchboard at another office.
- Completes the call to the line.

I will proceed in the context of that "basic scheme". In section 10, however, I will discuss an important variant.

6.2 The "A" switchboard

This portion of the article focuses on the "A" switchboard (not always mentioning that "type designation"). Later, we will deal with the differences in a "B" switchboard.



Figure 2. No. 1 common battery "A" switchboard

6.3 Positions and sections

The overall basic form of a manual telephone switchboard can be appreciated from Figure 2.

This shows a portion of a more modern installation than we saw in figure 3, a modest-sized Western Electric No. 1 common battery "A" switchboard, perhaps in the early 1950s. From this vantage point, a "B" switchboard would not look much different, although (as we will see later) there are significant differences in important details.

This switchboard evidently has a capacity of about 7600 lines. It is equipped for 22 *positions* (operator "workstations"). Its overall

physical construction is in modules called *sections*, each of which comprises three positions. This board has 8 sections, but two of the 24 potential position locations, one at each end, are not actually used for positions, for a reason that will become apparent later.



Figure 4. Automatic Electric common-battery switchboard (ca. 1947)

6.4 Switchboard physical architecture

The detailed arrangements of a position are well seen in Figure 4 (which is of a different kind of switchboard; it is in fact not a Western Electric switchboard but rather was made by Automatic Electric Company⁹, and was not in use in the Bell Telephone System, but rather by B.C. Telephone Company in Vancouver, British Columbia). It has been annotated for reference during the ensuing discussion.

By the way, although there were many subtle differences between the Western Electric and Automatic Electric switchboards, the overall concepts and general designs were almost identical.

We note that the position equipment here includes a dial, since at the era of this switchboard there were dial central offices in the metropolitan area, and the dial here was used in a certain type of

⁹ Yes, I'm a Western Electric *aficionado*, but also a sucker for cute girls.

interworking with them. The actual switchboards I will discuss here did not have a dial.

In front of the operator is a horizontal surface called the *key shelf*, behind which is a narrower horizontal surface called the *cord shelf*.¹⁰ Behind that is a vertical surface carrying many jacks, which we will call the *jack field*.

On the key shelf and cord shelf there are a number of *cord circuits* (often 15-17; 17 here, the most common quantity as a matter of fact), The visible parts of each take up a narrow front-to-back strip of key shelf/cord shelf surface. One is highlighted in white in the figure.

At each cord circuit (for idle ones) we see on the cord shelf two switchboard plugs (one behind the other), resting on resilient cushions in shallow cylindrical wells in the key shelf. Each is at the end of a long cord, the other end of which is connected to terminals on a bar running along the back of the switchboard (at about the height of the cord shelf).

Each cord, below the cord shelf, runs through a pulley on a thin iron weight. These weights serve to keep the cords under enough tension that they behave well when pulled out of the key shelf, and pull the cord, and thus the plug, down nicely into its resting position when the cord is no longer in use.

In front of the cords, on the key shelf, there are two indicator lamps. Their function will be described shortly.

Further to the front are two lever keys (lever-operated multiple-contact switches). Their functions will be described shortly.

To get a little ahead of the story, as you can guess, these cord circuits are used to make connections between a calling subscriber and a called subscriber (using the jacks in the jack field). But they are much more complex than "patch cords".

The two cords of each cord circuit are connected together by circuitry which:

- Feeds DC current to the stations to which the plugs are connected, to energize their transmitters (and for a second purpose that will be mentioned just below).

¹⁰ The reason for the division into two surfaces is that the key shelf can be lifted up on a piano hinge at its rear for maintenance of the wiring. The cord shelf is fixed.

- Provides a transmission path for the voice-frequency signals (“audio”) between the two stations (after all, the objective of their being connected).
- Monitors the flow of DC current through of the cords (and thus through each of the stations) in order to detect if either party has “hung up”.

Figure 5 shows a typical switchboard plug (said to be the “310 type”, after its Western Electric apparatus code, although the one shown was not necessarily made by Western Electric).



Figure 5. 310-type switchboard plug

The switchboard plugs carry three contacts, called (for obvious reasons) the *tip*, the *ring*, and the *sleeve*. The tip and ring will carry the actual two-wire telephone circuit into the jack and thence out over the line wires to the station.¹¹ The sleeve carries a control conductor that is only used inside the switchboard for various purposes we will discuss later.

If the tip and ring contacts were separated only by a small band of insulating material, then when the plug is being inserted into the jack, the ring contact spring in the jack (encountered first) could momentarily bridge the tip and ring contacts of the plug, perhaps causing an audible “pop” (in some uses of the plug, something worse).

We could avoid that by having a larger space between the plug tip and ring contacts, filled with insulating material. But the passage of that band of insulation under the contacts of the jacks, over thousands of insertions, could wear the relatively-soft insulating material.

Instead, we include in the jack makeup a brass ring insulated from the tip and ring contacts by tiny bands of insulating material. The ring is

¹¹ In fact, as a result, in U.S. telephone practice, the two conductors of the line itself are called the *tip* and *ring* conductors, and the control conductor which may accompany them the *sleeve* conductor.

not connected to anything (thus its name, *dead ring*¹²), but is a more durable wide separator between the tip and ring contacts than a wide band of insulating material.¹³

Perhaps when the plug is on its way in, the ring contact spring of the jack will first bridge the plug ring to the dead ring, and later bridge the dead ring to the ring, but not at the same time, so no short circuit from tip to ring will occur.

Although I explained the dead ring by saying that a wide band of insulating plastic between the tip contact and the end of the sleeve would wear too easily, in modern times, with better thermoplastic materials available, the plugs often do not have a dead ring but rather just a wide band of insulating plastic.

6.5 Supervisory lamps

And important part of the cord circuit is its two *supervisory lamps*, one associated with each cord. In figure 4, we see them just in front of the cord shelf.

After a call is set up, when one party or the other hangs up, the supervisor lamp for the cord connected to that party lights, alerting the operator that this call requires some attention. One of the lamps is also used to recognize when the called party has answered the call.

The name of these lamps comes from the fact that one of the duties of the operator is to *supervise* each call (that is, to “manage” it). A pivotal piece of information she needs to do this is whether the called party has answered yet, and after the call is set up, if either party has hung up. And that is what she learns from these lamps.

We’ll hear a lot more about these guys later.

6.6 The jack field

The jack field is organized into vertical panels. There are an integral number of panels per section, but not necessarily an integral number per position. For example, across a “section” (the module in which manual switchboards are manufactured) comprising three positions, there may be six panels (as seen in Figure 4), seven panels, or eight panels (as seen in Figure 2).

¹² But sometimes *dead collar*.

¹³ But in modern times, given the availability of more durable insulating material, some plugs (especially those not actually used in manual switchboards but rather on “patch cords”) have a separator wholly made of insulating material. Its overall span is the same as the “dead ring” and its adjacent insulating sections.

The jack field of this "A" switchboard has three principal areas, identified in the figures with white outlines.

The jacks are often in rows of 20, carried in an integrated strip (called a *jack mounting*). We see one "loose" in figure 6.

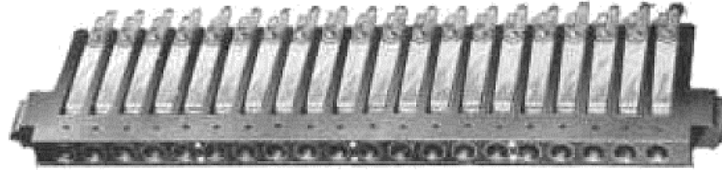

Figure 6. Switchboard jacks in mounting

Referring again to Figure 4, At the bottom of the jack field there are the *answering jacks*, these in rows of 10, each with an associated indicator lamp below each jack. We can see six rows of them (in each panel). As we will see shortly, these are used to make connection to a line requesting service.

Next up is the *trunk multiple*, which comprises jacks for trunks to other central offices. In this case, they are 20 to a row, and we see five rows of them (in each panel). More about them later. (We'll learn shortly about the significance of the term "multiple".)

Above that is the *line multiple*, which comprises jacks associated with subscriber lines, In this case, there are 20 to a row. The rows are arranged in blocks of five rows (with a small white stripe between them)¹⁴.

We'll take a closer look at two of the areas later, after the story begins to unfold, and a third one later yet.

6.7 Jack spacing

In the earliest switchboards of the basic design we are examining (perhaps *ca.* 1897), the plugs had a finger diameter of 0.250" (1/4"). The jacks were at a spacing of 1/2" along the mountings, and the mountings were 1/2" thick, resulting in a general vertical spacing of 1/2", so the jack pitch was 1/2" along both axes.¹⁵

¹⁴ The white stripe actually comes from a thin sheet of white wood (plastic today) sandwiched between two adjacent strips of jacks (but fastened to the upper one), called a *holly strip*, since initially holly wood was used for the purpose.

¹⁵ All horizontal spacings mentioned here are for the case where there are 20 jacks in each strip.

By 1905, an improved form of that plug¹⁶ came into use. Its shell had a diameter that was just shy of $7/16$ ". At about that time in switchboards using this type of plug, the spacing (both vertical and horizontal) was decreased to $7/16$ ", thus allowing a modest increase in the number of multiple jacks that could be accommodated in the jack space.¹⁷ With this design, the effective width of a panel (including allowance for the stile strips between them) is about 10.25 inches.

But in 1904 a smaller version of that plug¹⁸ also came into use, with a finger diameter of 0.207", and a correspondingly-smaller shell (with a diameter just shy of $3/8$ "). This allowed the adoption of a jack spacing of $3/8$ " both vertical and horizontal.¹⁷ With this design, the effective width of a panel (including allowance for the stile strips between them) is about 8.5 inches.

This allowed an increase in the maximum capacity of the switchboards. I won't mention any capacity numbers yet, as there is a complication in doing so. I will get back to that after the complication is discussed (see section 13).



Figure 7. Western Electric 52A headset

6.8 The operator's telephone set

Each operator is equipped with a special type of telephone set, which manifests (in modern times) with a headset, which incorporates a

¹⁶ For example, the Western Electric 110 type, later superseded by the 310 type.

¹⁷ No, there wasn't much clearance between adjacent plug shells!

¹⁸ For example, the Western Electric 109 type, later superseded by the 309 type.

receiver ("earphone") on a headband and a small transmitter ("microphone") supported on a thin "boom" supported by the receiver housing.

We see an example of such an operator's headset in Figure 7.

A bit earlier in time, the transmitter of the operator's telephone set, equipped with a horn-like mouthpiece, was mounted on a breastplate which, like some gigantic pendant, was supported by a strap around the operator's neck. In fact, we see just that in Figure 4.

Even earlier, the transmitter dangled in front of the operator on its two leads from an overhead boom. We see that in figure 8 (on a magneto switchboard).

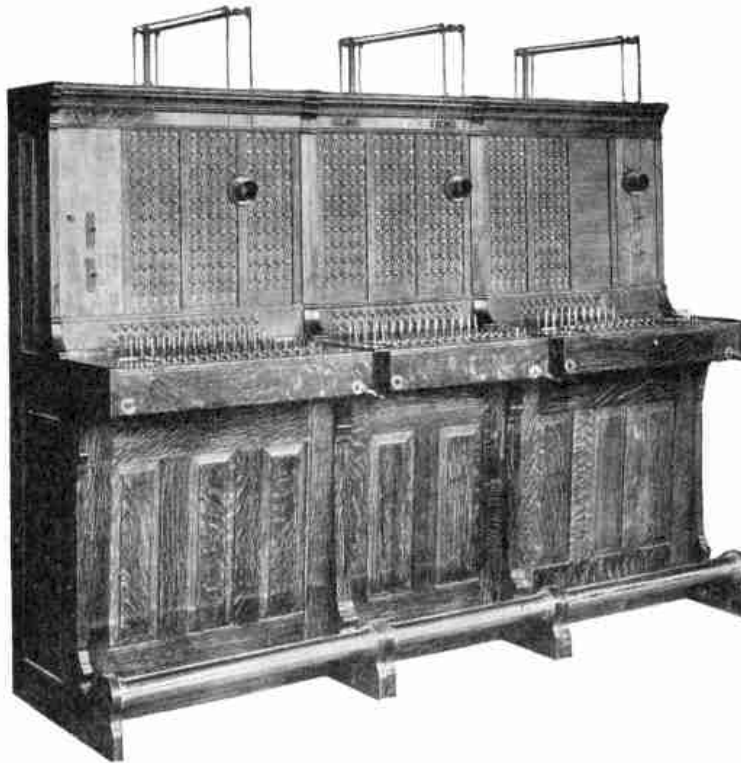

Figure 8. Three-position switchboard with suspended transmitters

In any case, the transmission circuitry for the operator's telephone set is located in an equipment rack at the rear of the position. The transmitter is energized by DC from the switchboard "battery" system.

Setting aside the suspended transmitter arrangement, the operator's headset has a cord ending in a plug with two 0.250" diameter tip-sleeve plugs, spaced 5/8" on center. Figure 9 shows a relatively modern version of this.



Figure 9. Headset plug (modern design)

This is plugged into a “jack” (actually, a pair of jacks) mounted on 5/8” centers in a block at the left side of the front “fascia” of the switchboard¹⁹. The two “plugs” in the “plug” are mounted with a little bit of “float” so they can self-align with the two “jacks” in the “jack” in the face of small dimensional variations.

The receiver of the headset is connected across the two sleeve contacts and the transmitter across the two tip contacts. With this arrangement, as the plug is being inserted in the jack, the receiver never becomes momentarily connected to the transmitter circuit, on which a DC voltage appears (which might damage the receiver, and at the least would cause it to emit a loud “pop”). The transmitter will be momentarily connected to the receiver circuit, but there is no mischief in that.

In fact, there are two sets of jacks in that jack mounting, so two headsets could be plugged in at the same time. This was mostly used at the time of shift change, or break time, when the “relieving” operator could plug in her headset²⁰ when she arrived and “pick up on the action” before the “retiring” operator unplugged.

¹⁹ That “fascia” is formally called the *lockrail*, a term that goes back to early switchboards, which had there a little lock (evocative of that on a roll-top desk) that would keep anyone but a proper technician from lifting the keyshelf. Of course the notion that an operator would be so fascinated by the working of the switchboard that she would surreptitiously lift the keyshelf and poke at what was on its underside was recognized as silly, and so over time the locks disappeared. But the memory lives on in the name of that part of the switchboard.

²⁰ Operators in general were assigned their own headsets, in part so that custom adjustments in the headband could be retained, and in part for “hygiene” reasons.

6.9 Supervisors

In figures 1 and 2 we see some women we can recognize as supervisors. One of their task of course was to oversee the operation of the switchboard, making sure that the proper positions were occupied and that the operators followed the proper procedures (and decorum). But another important task was to assist the operators when needed in dealing with a troublesome call (perhasps a troublesome caller).

Over time, the provisions for supporting this duty became more complicated and sophisticated. Initially, there was at each position a key the would light an indicator light at the top of her position, summoning the supervisor for that "division" of the switchboard to come to the operator's side. If the situation required the supervisor to speak with the caller, the supervisor would plug her headset into the position, in the "second" jack we spoke of before.

Later, there were provisions so the supervisor could do these tasks without leaving her chair. Her headset, which typically had a long cord, was more-or-less permanently plugged in into the switchboard, not into the "second" headset jacks of a particular position but rather into a separate *supervisor's headset jack*. These were typically located at the right end of the lock rail every so many positions apart. We can see this in effect in figure 10. (I think this is actually a large PBX, possibly at the U.S. Capitol, *ca.*1959.)



Figure 10. Supervisors plugged in

If the operator needed to ask a question of the supervisor, she would operate a special key that took her telephone set off whichever cord circuit it was connected to through the cord circuit talk key and connected it to sort of an intercom circuit to the supervisor's telephone set. If then it seemed necessary for the supervisor to speak to the caller, the operator operated that key in the other direction, which that put her telephone set back in touch with the cord circuit and connected the operator's telephone set to it as well.

7 THE TELEPHONE SET AND THE LINE CIRCUIT

Before we proceed to the matter of call handling, we need to learn a bit about the client (in the technical sense) of the operation, the subscriber's telephone set, and of one aspect of how it interfaces with the switchboard.

7.1 The telephone set

Figure 11 shows the basic conceptual circuit of a typical common battery telephone set for use in a manual switching system.

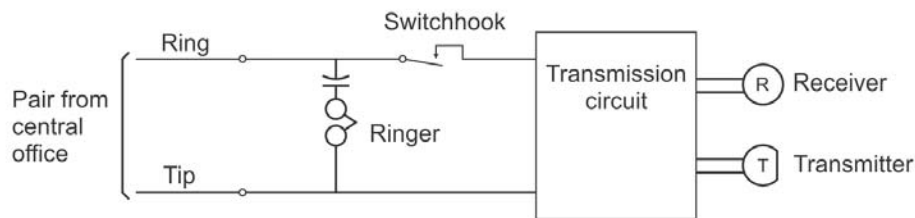

Figure 11. Basic telephone set circuit (individual line station)

The transmission circuit comprises a transformer, capacitors, resistors, and so forth. It is used to couple the receiver and transmitter to the line. It does this in such a way that the voice signals from the transmitter do not come back into the receiver at "full strength" (an arrangement called an "anti-sidetone" circuit, *sidetone* referring to the speaker's voice coming out of his own receiver, a phenomenon that is good but only if it is not "too strong"). The transmission circuit also arranges for the DC current that flows in the line when the set is active to pass through the transmitter itself, energizing it.²¹

The switchhook contact is operated by plungers or such in the handset cradle. When the handset is "on hook", the contact is open, and there is no path through the transmission circuit. When the

²¹ The traditional telephone set transmitter operates on a variable-resistance principle (it is called in other contexts as a "carbon microphone"). It must have a DC current through it to generate a signal.

handset is “off hook”, the contact is closed, and that path is completed.²²

The ringer (that is, its coil), in series with a capacitor, is connected from one line conductor to the other. Why the capacitor? As we heard earlier, in common-battery operation we depend on whether or not current flows in the line (propelled by the DC voltage across the line) to know whether or not the station is off hook. The capacitor blocks the flow of any DC current through the ringer. Such a current would, among other things, destroy the ability to know whether the station was off hook or not.

But the “business end” of the ringing signal is an AC voltage. The impedance of the capacitor at the ringing voltage frequency is fairly low, so the ringing voltage reaches the ringer.

7.2 The line circuit

At the switchboard, each line is connected to a *line circuit*, and then through it to the applicable jack strings. When the line is idle (meaning when no cord circuit is plugged into it), battery (-24 V DC) is connected to the ring conductor through the winding of a *line relay*. Ground is connected to the tip conductor.

Figure 12 shows the circuit of an illustrative line circuit.

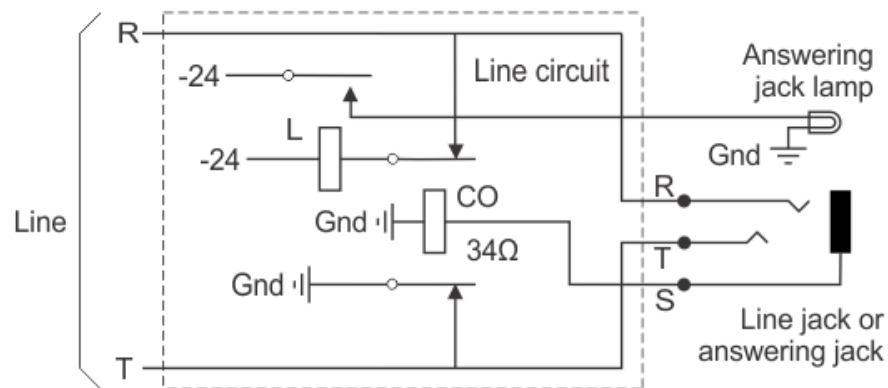

Figure 12. Common battery manual switching line circuit

We’ll learn more about its life shortly.

²² The figure omits various details not pertinent to the story here, such as a switchhook contact to mute the receiver while the switchhook line contact is opening or closing (to prevent “pops” in the ear), and so forth.

8 HANDLING AN INTRAOFFICE CALL

8.1 Definition

An *intraoffice* call is one in which the called party is served by the same switchboard (central office) as the calling party. We can follow the action in figure 13.

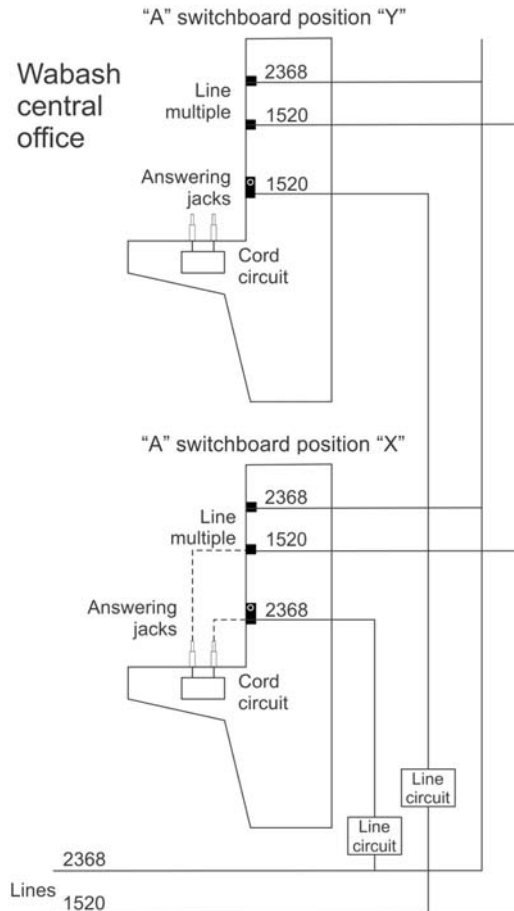

Figure 13. "A" switchboard positions

The figure shows two "A" switchboard positions, called for our purpose "X" and "Y", in the Wabash central office, and two lines, whose numbers are 2368 and 1520.

8.2 The line multiple

Every line served by the switchboard is connected to several jacks in the jack field (all of them electrically in parallel) spaced out along the length of the entire switchboard (perhaps at a spacing of between 2 and 3 position widths). This arrangement is called a *multiple jack*

arrangement, a rather obvious name.²³ Actually, the whole collection of multiple jacks in the entire switchboard is called *the multiple* (more explicitly in this case, the *line multiple*).

The overall result is that, if any operator is trying to “complete” a call to a certain line, a jack for that line will be found, in the line multiple, either in her position or within her reach in the adjacent position to the left or right (a “boarding house reach” being a necessary skill for operators).

The drawing suggests that one of the multiple jacks for line 2368 and one for line 1520 both appear at positions “X” and “Y”. Maybe that is actually so, but more generally there is one of those jacks “within the reach of” the operators at those positions. And of course the drawing suggests that there are further jacks for those two lines. If the switchboard has 75 positions, there may be about 25 “appearances” of every line.

8.3 The answering jack field

Each line served by this switchboard is also connected to (lets say for now) a single jack²⁴, with an indicating lamp just below it, in the answering jack area, in front of a particular operator. In a switchboard of this size, there may be 320 or so of these answering jacks “in front of” each operator. The path to this jack and its lamp is through the line circuit.

The lines are not assigned to these jacks in order of telephone number, but rather in a scheme that takes into account the different calling habits of various classes of line (how heavy the calling traffic from a line of that class is expected to be).

In figure 14 we see a part of a typical answering jack field.

²³ And because the multiple jacks for one line are electrically connected in parallel, for a long time when describing circuits for telephone equipment, if two or more components (maybe even resistors) were connected in parallel, it was said that they were connected “in multiple”.

²⁴ We will learn later that in actuality there are two or even three answering jacks to which the line is connected, but for the moment we will think of it as only a single answering jack.

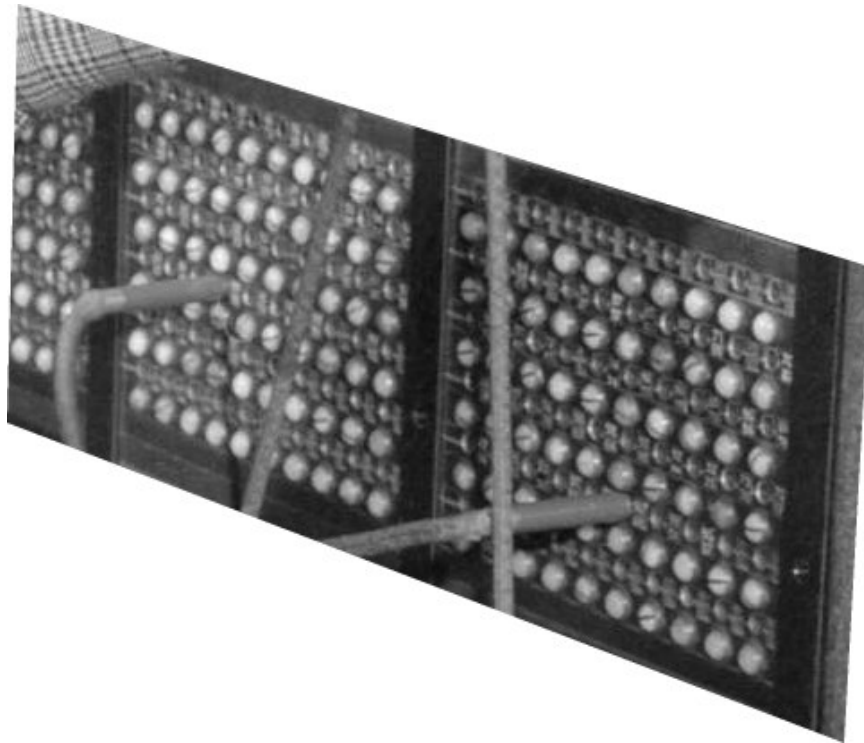

Figure 14. Part of typical answering jack field

(Apologies for the poor resolution of the photo.)

We see that the answering jacks (with their associated lamps) are mounted 10 to the strip, rather than the 20 per strip mounting we will later usually see for other portions of the jack field. There are not a large number of answering jacks at each position, so this less dense packing does not result in a gigantic escalation of the space required, and makes it easier for the operators to work with the answering jacks (as well as allowing for a larger cap for the indicating lamp).

The different markings on the lamp caps serve to indicate properties of the line, perhaps pertaining to what we would call today its “rate plan”.

8.4 The cord circuit

An important player in the following drama is a *cord circuit* of the switchboard. We see these in person on figure 4. We will soon hear of their operation.

8.5 Placing a call

When a subscriber wishes to place a call, and takes the receiver of his telephone set “off the hook”, a DC path through the telephone set is completed, and current flows in the line (propelled by the DC voltage placed across the line by its line circuit). That flow is detected by the line (L) relay (see figure 12). This causes the lamp below the associated answering jack to light, alerting the operator that the

subscriber whose line is connected to that answering jack wishes to place a call.

The operator takes to hand the “back cord” (furthest from her) of an idle cord circuit, pushes the *talking key* for that circuit (the rearmost key) away from her (this connects her telephone set to that cord circuit), and plugs the cord into the answering jack. The answering jack lamp is extinguished (we’ll see how in a minute). The operator is now in communication with the calling subscriber, to whom she says “Number, please”.²⁵

The caller gives the desired number, which we assume in this case is served by this same switchboard (same central office).

8.6 Inside the cord circuit

In figure 15 we see the illustrative line circuit again, but this time we also see some of the fundamentals of the cord circuit.

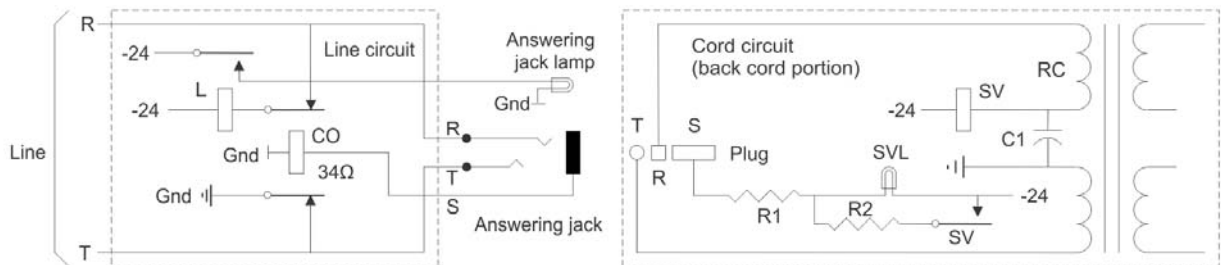

Figure 15. Line circuit and cord circuit (back cord portion)

We see here only half of the cord circuit (the part for the back cord). The talking key and the operator’s telephone set are not shown, as they are not directly pertinent to the topic of this section.

RC is a *repeating coil*²⁶ (telephonese for an audio coupling transformer). It will provide for the transmission of speech between the front and back cords (in either direction) once the call is completed.

Each of its two (identical) windings are split in the center. We see that battery (-24 V) and ground are fed into the “inner ends” of the winding for the back cord. They pass through the respective halves of the winding to the ring and tip (respectively) of the cord plug. Battery is fed through a low-resistance supervisory relay (SV). Its job (once

²⁵ In a metropolitan system; in a very small town, perhaps, “What can I do for ya, Joanne?”

²⁶ Often just called a “repeat coil”.

the cord is plugged into a jack for a line) is to determine whether there is any current flowing in the line, and thus whether or not the station is off-hook.

We do not want any of the speech voltage passing through the cord circuit to be lost in drop across the impedance of the supervisory relay, so bypass capacitor C1 "shunts out" the relay coil insofar as speech-frequency signals are concerned.²⁷

8.7 Cutoff

When the operator plugs the back cord of a cord circuit into the answering jack, current flows from battery through the back cord supervisory lamp SVL and resistor R1 to the sleeve contact of the back cord plug, and thus the sleeve contact of the jack, into the sleeve lead, which goes to the line circuit. There it operates the *cutoff relay*, CO. I show its resistance since it is significant that it is low.

The CO relay, when operated, removes the battery (through the winding of the line relay) from the ring of the line and the ground from the tip. The line circuit has now devolved into just a "clean" path for the ring and tip conductors of the line, through the answering jack, to the "back cord" portion of the cord circuit.

Now the cord circuit furnishes battery and ground to the line, and will do so for the duration of the connection.

The path through the sleeve to the line circuit completes the circuit through the supervisory lamp, so that lamp could now light. But in fact, since the calling station is off-hook, at this point current flows through the line, operating supervisory relay SV. Its contact short-circuits the supervisory lamp through resistor R2. Its resistance is low enough that while a small current still flows through the lamp, it is not enough to make it emit visible light. The reason for this small current will be described shortly.

Of course when the path through the line relay coil (L) is broken by the operation of the cutoff relay (CO), the line relay releases, This is what extinguished the answering jack light.

We will pick up the life of the cord circuit in a little while.

²⁷ Sometimes a resistor is put across the relay winding as a "partial solution" to this matter.

8.8 The multiple in more detail

The jacks in the multiple are organized by telephone number. If we refer to Figure 4, we will see (as mentioned in Section 6.6) that the multiple jacks are in strips of 20, with five consecutive strips (100 jacks) forming a block, the blocks separated by white "holly strips".

To the left of each block is a circular number plate, This gives the thousands and hundreds digit for the block of jacks.²⁸

On one strip, groups of five jacks are separated by a pair of white dots, making it easy for the operator to easily reckon where a particular number falls in the block.

For example, if the number wanted is 2347, the operator goes to the block whose number plate carries "23", goes to the third strip from the bottom (4x-5x), goes to the second group of 5 jacks (45-49), and zeros in on the third jack (47).

Typically small numbers, 00-99, are engraved to the right of each jack in the block, to facilitate identification of the proper jack. We see these in Figure 16.



Figure 16. Multiple jack numbering

But of course experienced operators didn't need them!

The blocks start at the lower edge of the multiple area and at the left edge of the "multiple repeat". That first block has number plate "00" (and thus has jacks for lines 0000-0099, which bear the number markings 00-99)). Just to its right (in the next panel) is block "1". Assume for the moment that the multiple repeat is 8 panels. Then block "07" will be the rightmost one in this multiple repeat.

Thus just above block "00" will be block "08", and block "09" is just to its right.

If the total capacity of the switchboard is 3200 lines, there will be 32 jack blocks in each multiple repeat, 4 in each of the 8 panels. The topmost block in the rightmost of the 8 panels in the multiple repeat

²⁸ This assumes that the office basically uses four-digit telephone numbers. An office with less than 1000 subscribers might only use three digit numbers.

will have number plate “31”, and will have the jacks for lines with numbers 3100 through 3199.

Then, in the next set of 8 panels to the right (the next “multiple repeat”), this scheme will repeat all over.

8.9 Completing the call

Our operator’s next task will be to take the front cord of the chosen cord circuit (sometimes called the *completing cord*) and plug it into a multiple jack for the wanted line (that is, a jack bearing that line’s telephone number).

Will that be in front of her position? Not necessarily. But if the “pitch” of the multiple appearance of the line (the width of the “multiple repeat”) is one section (3 positions), it will at worst be almost at the far left of the position to her left or the far right of the position to her right—within her “boarding house reach”.

8.10 The busy test

When the operator goes to plug the front cord into a multiple jack for the called telephone number, how does she know that the subscriber is not already involved in a connection?

Now, we have to get back into a little circuitry. We’ll follow this action on figure 17, in which the half of the cord circuit that is shown is for the front cord.

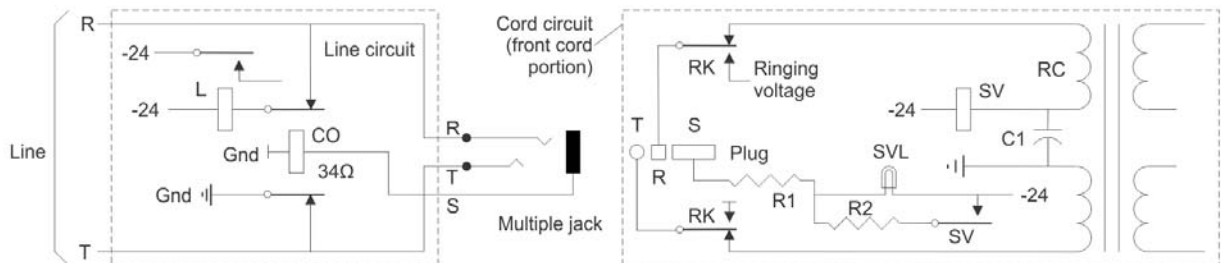

Figure 17. Line circuit and cord circuit (front cord portion)

Recall that when a cord circuit cord is plugged into a jack (*answering* or *multiple*, it turns out), current flows from the sleeve of the cord to the line circuit, where it operates the cutoff relay. And that current through the relatively-low resistance of the cutoff relay takes the sleeve conductor to a voltage of perhaps -4 V.

The result is that, for a line that is “busy”, the sleeve contacts of all the multiple jacks for the line, and its answering jack(s), exhibit this voltage.

Now let's consider the cord circuit. We recall that for the front cord (back cord as well) battery and ground are fed, through windings of the repeat coil to the ring and tip, respectively, of the plug. We will see shortly why it is that particular way.

With the plug not yet inserted in a jack, there is no current flow through the "talking battery feed" path, and thus no voltage drop in those resistances, and thus the "open circuit voltage" on the ring contact is -24 V , and on the tip contact, 0 V .

As the operator begins to insert the plug, it is almost inevitable that the tip of the plug will first make contact with the sleeve of the jack; in fact, the operator uses a special maneuver to ensure that. (This process is called the *busy test*, for a reason we will see shortly.)

As I just mentioned, if the line is busy, the voltage on the jack sleeve will be about -4 V , and since the voltage on the plug tip is 0 V , a small current will (suddenly) flow through the winding of the coupling transformer, making a prominent "click" which the operator hears in her telephone set. (The caller hears it too.) This alerts the operator that the line is busy, and she does not insert the plug in the jack.

Instead, she drops the front cord (the weighted pulley pulling it smartly into its parking position on the key shelf) and advises the caller, "That line is busy." If the caller does not, for example, say that she wants to try another number instead, but rather hangs up (which the operator know by the lighting of the back cord supervisory lamp), the operator pulls the back cord out of the answering jack and restores the talking key to disconnect her telephone set from that cord circuit.

Note that this operation depends on the voltage on the tip of the plug, when the plug is not yet in a jack, being zero (so the small voltage on the sleeve for a busy line will cause a current flow in the repeat coil and thus make a click). This is why the talking voltage is applied with ground on the tip and thus battery on the ring.

It is this that lead to the convention, still widely followed in telephone circuits in all contexts, of the battery being on the ring and ground on the tip.

8.11 The called line is not busy

Suppose the operator does not hear the click that tells the line is busy. She plugs the front cord into the multiple jack. There's little bit of art to that.

Suppose that when the operator is about to make the "busy test", she has pulled just enough cord out that the tip of the plug can just be

touched to the sleeve of the jack (with the plug more-or-less continuing the line of the cord; that is, pointing "upwards"). Then, if the line is not busy, she must lift the "butt" of the plug (the part nearest the cord) a little until the plug is level, so its "finger" can enter the jack.

This of course requires a little more slack to be pulled in the cord, not as simple as it sounds because of the friction required to start the cord moving (especially if the cord leaves the key shelf at an angle because the target jack is off to the side).

So the operator uses a special maneuver for the whole operation, seen in figure 18.

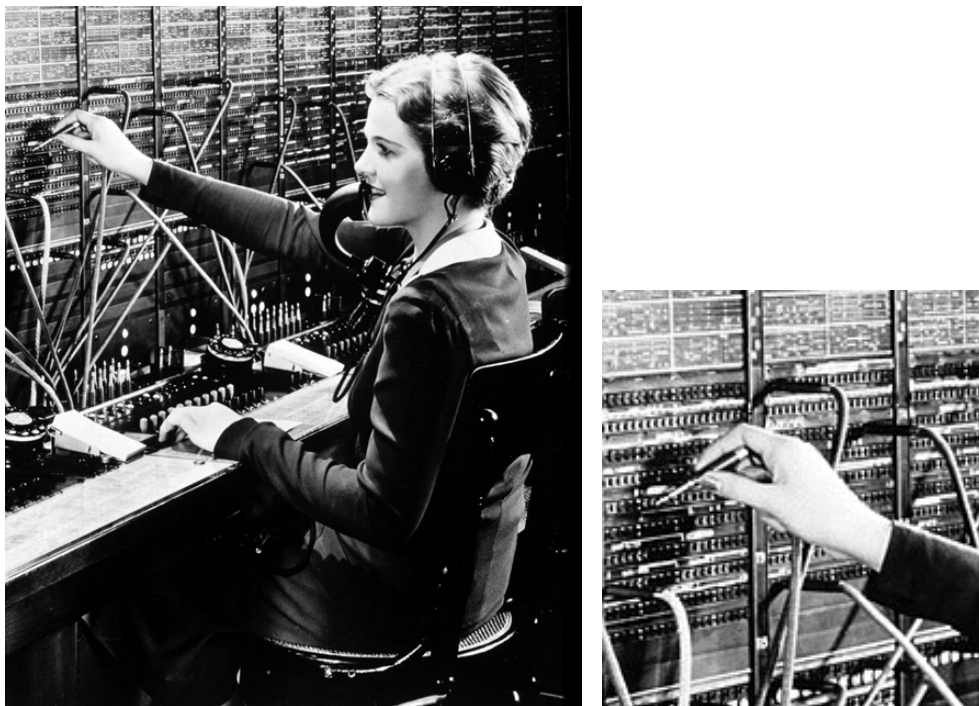

Figure 18. Busy test maneuver.

She takes the front cord and pulls enough slack that the butt of the plug is a bit above the target jack (and typically a bit to the side so her hand does not block the view of the jack), and angles the plug down (and a little to the side) to touch its tip to the sleeve of the jack to make the busy test.

Then, if the line is not busy, she can easily move the butt of the plug down just a little until it is level and aligned with the jack (the cord does not fight that mostly-downward movement) and plug into the jack.

In the same way we earlier saw when the back cord is plugged into the answering jack for a calling station, when the front cord is plugged into the multiple jack for the called station, current flows through the

cord sleeve and the sleeve contact of the jack into the sleeve lead and thus to the CO relay of the line circuit. There, as before, the CO relay removes from the line the "idle" connection to battery and ground through the L relay (clearing the path to the called station from the front cord portion of the cord circuit).

And, as before, this has the effect of putting the sleeve conductor to a voltage of perhaps -4 V. so that the line will "test busy" to any other operator seeking to make a connection to that line.

And, as before, the current flow through the sleeve of the cord flows through the front cord supervisory lamp circuit.

In this case, the called station is, for the moment, on-hook. Thus the front cord supervisory relay (again SV in this figure) does not operate. The front cord supervisory lamp is not short-circuited with a resistor, so it lights. This of course tells the operator that the station to which the front cord is now connected (the called station) is still on-hook (certainly expected at this point in the scenario).

8.12 Ringing the called station

After the operator has plugged the front cord into the calling line, in the simplest type of switchboard, she "manually" rings the called station by momentarily pulling the ringing key of the cord circuit (the rearmost key) toward her. (It is a "momentary" type key, which returns to its normal position if we let go of the handle.) Its contacts (RK in the figure) take the tip and ring of the plug off the battery feed/talking circuit, and instead connects them to the AC ringing voltage (on the ring) and ground (on the tip). She can do this repeatedly, if needed. When the station answers (the front cord supervisory lamp will go out), she stops doing that.

This of course requires a lot of attention on the part of the operator, and limits the number of calls she can complete in any period of time.

For that reason, many switchboards came to have *machine ringing* capability. (The figure does not show this at all.) In such switchboards, as soon as the front cord is connected (the cord circuit can tell that by the flow of current in the sleeve conductor), a relay is operated that disconnects the tip and ring of the plug from the battery feed/talking circuit and instead connects them to a "machine ringing" source (and ground). This source has ringing voltage on it for two

seconds, and then no ringing voltage (but instead a constant DC voltage) for four seconds.²⁹

The ringing voltage proper consists of the expected AC component (20 Hz, perhaps 75-115 V RMS) plus a DC component (often -48 V). The "silent interval" voltage then consists just of -48 V.

The ringing signal is fed through a *ringing trip relay* (often spoken of as just a *trip relay*) in the cord circuit. This is a relay that is insensitive to an AC current component, but responds to a DC component.

As we saw earlier, at the telephone set, there is a capacitor in series with the coil of the ringer, so while the ringing/not ringing pattern is sent out, although there is a DC component to its voltage, there can be no DC component of the resulting current in the line, only an AC component. The trip relay does not respond to this AC current.

When the called subscriber answers, the telephone set transmission circuit is connected to the line, It of course affords a path for DC current, and under the influence of the DC component of the ringing or "silent interval" voltage (whichever is in effect at the instant of answer), a DC current flows, which operates the trip relay. This shifts the cord circuit back into the battery feed/talking mode, and the connection is ready for conversation.

In the case of either manual ringing or automatic ringing switchboards, the operator can always send ringing voltage on the back cord (ordinarily connected to the calling party) by pushing the ringing key toward the back, and on the front cord (ordinarily connected to the called party) by pulling the ringing key toward the front.

8.13 Answer

When the called station answers (and if we have machine ringing, the trip relay has operated), current flows from the front cord portion of the cord circuit through the line and through the transmission circuit of the station set. This operates the front cord supervisory relay, which short-circuits the front cord supervisory lamp, which goes dark. Thus during the conversation, with both calling and called stations off hook, both supervisory lamps are dark. Essentially, at this point, the operator need give no attention to the call.

²⁹ Thus "machine ringing" came to have two related but distinct meanings: (a) automatically starting and then ending the application of the ringing signal once a connection has been made to the called line, and (b) a ringing signal in which there was a "cadence" of ringing intervals interspersed with silent intervals.

This might be a good time to mention why the convention is that the supervisory lamps light when the station is on-hook rather than when it is off-hook. The reason is that of course, for cord circuits that are active, they are most of the time involved in actual conversations between two parties (both of them thus off-hook), and so most of the supervisory lamps are dark. It is only when one party or the other hangs up (goes on-hook) that the supervisory lamp lights. This is then quickly visible to the operator, who now needs to give that call some sort of attention.

And of course this way of working also minimizes the energy consumed by the lighted supervisory lamps.

8.14 Ending the call

When, their conversation being finished, one party or the other or both hangs up, the associated supervisory relay releases, removing the short circuit from the associated supervisory lamp, which lights. This alerts the operator that some attention is needed to the call.

If in fact both supervisory lamps are lit within a few seconds, it is clear that the parties are indeed done for the moment. The operator pulls both cords from their jacks. The supervisory lamps go dark, as their circuit requires a path through the sleeve of the respective plug, and there is no longer such a path.

At both line circuits, the lack of any current in the sleeve conductor releases the CO relay, which restores the "idle" situation of battery through the L relay on the ring and ground on the tip. Thus the line circuit is prepared to recognize if the party subsequently lifts the handset to make a new call.

At all the jacks for both lines, the sleeve voltage is now essentially zero, so the line will "test idle" to any operator seeking to deliver a call to it.

If one supervisory lamp lights but the other does not light within a few seconds, the operator realizes that the party that is still off hook (the one whose supervisory lamp is still dark) probably want to do some more business with the operator. She operates the talking key for the cord circuit and says, perhaps, "May I help you?".

8.15 More about the supervisory lamps

As I mentioned, the current path to the supervisory lamps are "energized" by the associated cord being plugged into a line, but if current flows in the supervisory relay for that cord (because the associated telephone set is off hook), the supervisory relay operates and "short-circuits" the supervisory lamp, preventing it from lighting.

But not exactly. We in fact saw that the “short circuit” is actually through a small resistance. Why is it done that way?

We saw earlier that when either party on a connection hangs up, the corresponding supervisory lamp lights. If both are lit within a few seconds, (both parties have “hung up”) the operator “pulls down the connection”.

The supervisory lamps have carbon filaments, like those of the earliest Edison lamps. These have very long life (under the conditions at which the lamps are energized). Another advantage is that carbon filament lamps have a high resistance when cold, and thus there is no high inrush current when they are first energized, as there is for tungsten-filament lamps, which have a low resistance when cold. This alleviates various possible bad effects.

A byproduct of this is that the “ramp-up” of lamp output is relatively slow (the “delay” being perhaps 50 milliseconds). This means that there would be 50 milliseconds of extra delay before the operator realized that one party had hung up. This may not seem like much. But added up over the millions of calls handled every day, across the entire telephone network, this ever so slightly dilutes the operators’ efficiency, over the entire network leading to a measurable escalation of the number of positions required to properly handle all the traffic, thus leading to greater overall capital costs and labor expense.

To mitigate this, when a cord is plugged in, and its supervisory lamp circuit is “activated”, but the supervisory relay is operated so the supervisory lamp is not to be lit, the lamp is really not short-circuited, but rather is shunted by a small resistance. In this situation, a small current passes through the lamp, not enough that it emits visible light but “preheating” its filament and thereby decreasing its resistance a bit, so that, when it is fully energized (when the party hangs up and the associated supervisor relay releases), its light output will “ramp up” much quicker.

8.16 Another look

With this background in the scenario at hand, it is perhaps of interest to take a look at an “A” switchboard jackfield from a different perspective (figure 19).

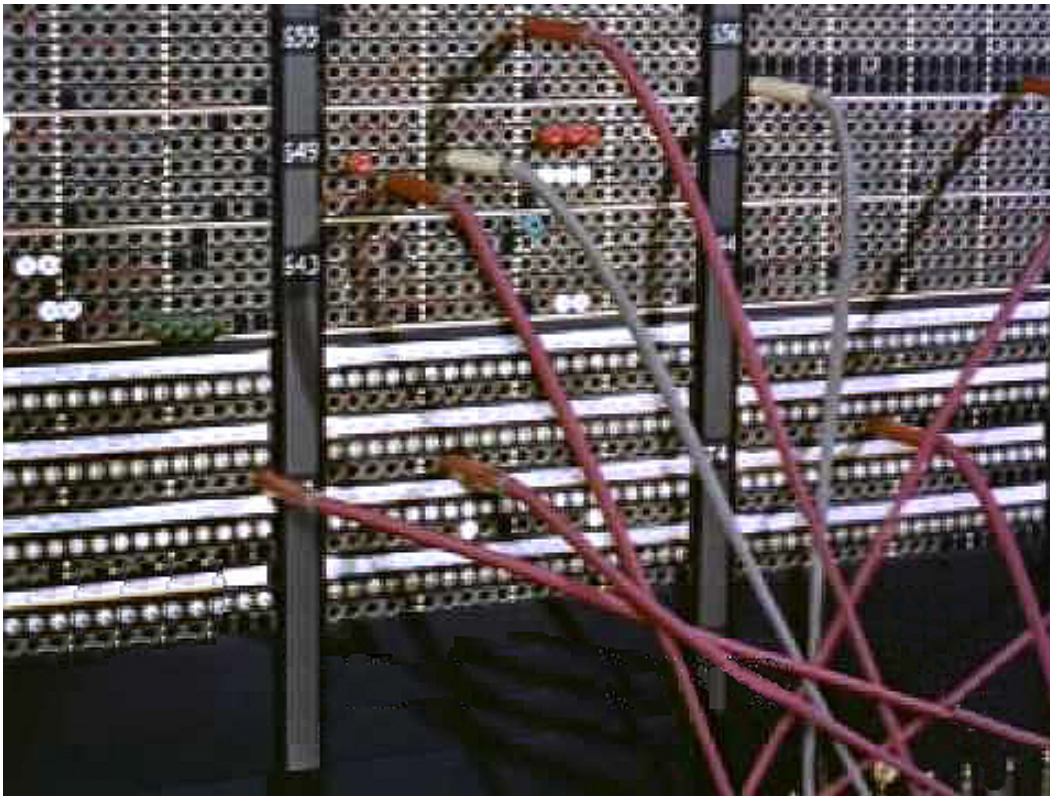

Figure 19. View of an "A" switchboard jackfield

We see here (at the bottom) the answering jack area (with the lamps and designation strips, here in strips of 10) and (above it) part of the line multiple area. A number of connections are up. We see here clearly a feature we could not very well see in the earlier photos (in black and white). Alternate cord circuits either have cords with a red jacket and a red shell on the plug, or with a "slate" (gray) jacket and a slate shell on the plug. This helps the operator to more easily keep track of which cords are which. The supervisory lamps on the cord circuits are red or white to match. There were of course numerous variations on this basic theme.

The designation strips on the answering jacks identify the line for that jack (they are not necessarily in order of line number here).

We see here fairly clearly that the line multiple jack "blocks" (each handling 100 lines) were identified by little nameplates on the stile strip to the left of the block. But the markings here are a bit surprising (again, this is no doubt some special type of switchboard).

Some of the jacks in the line multiple contain little colored "plugs". These indicate that the line is "out of service", the color indicating for what reason.

8.17 Ancillary answering jacks

I said before that each line was connected to many "multiple" appearances and as well to one "answering jack" appearance. That is not usually exactly so.

This arrangement as described means that when a particular line lifts the receiver to request service, only one operator can respond to it.

It is not desirable to plan for the operator at an adjacent position to handle the call, even if she could actually reach the answering jack, as it does not work out well for cords to go from position to position into a jack located low on the jackfield, as the answering jacks usually are.

There are several problems with this. For one, if that lamp should burn out (heaven forbid, but it can happen), that line is just out of luck insofar as making calls is concerned.

This also means, that if the "lucky" operator happens to be handling a complicated call at the time, there might be some delay before she can answer the new call (even though there may be many other idle operators).

To mitigate these problems, most switchboards have each line connected to two answering jacks. The additional answering jacks (called *ancillary answering jacks*) are located perhaps one "multiple repeat" to the right from the primary answering jack. Thus the operator at that position can answer the call if need be.

The ancillary answering jacks are placed in a separate vertical "layer" from the primary answering jacks. This way, the operator can tell the difference between which are (for her) "primary" answering jacks and which are ancillary answering jacks..

When an operator sees an ancillary answering jack at her position light, she does not grab that call right away (so the operator at the "primary answering jack" can get it if possible). But if the lamp stays lit for more than a few seconds, then this "second up" operator takes the call.

This of course consumes more vertical space in the switchboard panels than if there were only a single answering jack appearance for each line.

8.18 Dummy positions

We have seen how the full range of multiple jacks (that is, covering all lines) is not all directly in front of a given operator's position but covers a span extending partway across the adjacent positions to the

left and right (if we think of a span centered on the operator's position). In some setups this span may extend to a full position width to each side beyond the boundaries of the operator's position.

But how about the leftmost position? In that case there is no adjacent position to its left. So for the operator at that position, the full range of multiple jacks would extend from the far left of her position to about 2.0 position widths beyond the right boundary of the operator's position, certainly not practical for the operator to reach. The complementary problem would exist for the rightmost position.

To avoid this situation, there is a "dummy" position (my term) at the far left end of the switchboard and another at the far right end. These do not have any cord circuits, and are not occupied by any operator. But the subscriber line multiple extends into them enough that the operators at the leftmost and rightmost "real" positions have full multiple repeats centered on their positions.

In rare cases, these dummy positions are not based on the frame of a real position but on a narrower frame, suited for their reduced complement of panels.

Sometimes the amount of "overhang" needed into the dummy sections is not an integral number of panels. In that case, the number of panels provided in the end section may constitute more multiple than is actually needed by the operator at the adjacent "real" position, but there is no harm to that.

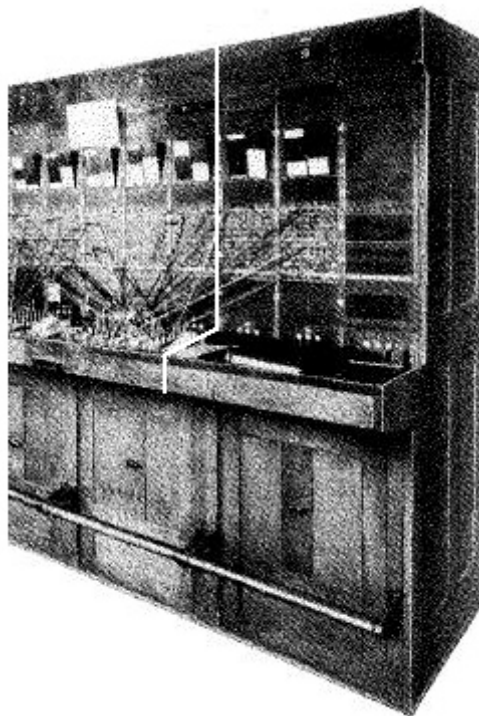

Figure 20. No. 11 switchboard—dummy position

In fact we see just that in Figure 20, which shows the right-end dummy position of a No. 11 manual switchboard (separated from the previous position by a white line). The multiple repeat in that type of switchboard is 2 positions, and so we would need in theory half a position worth of multiple overhang into each dummy position. But the setup here is 3 panels per position, so that would be 1.5 panels. We cannot reasonably implement a half a panel of multiple. So 2 panels of multiple are provided in the dummy positions.

8.19 The cable turning section

The cables to the switchboard from the distributing frames typically come through the back wall behind the switchboard or perhaps up through the floor or down from the ceiling. It would be very rare for them to enter the switchboard lineup on an "inline" basis from the far left or right. So they must usually make a 90° turn, one way or the other, as they enter the switchboard lineup proper.

These "bundles" of cables are quite gigantic. Keep in mind that if we only consider the cables to the line multiple, there is typically one cable in the bundle for every 20 lines, or, for a 9600-line switchboard, 480 cables. (We can see the full horror of this a little later, on Figure 28 in Section 13.)

Thus the turn takes up a fair amount of space. It takes place in a *cable turning section*, located at the appropriate end of the switchboard proper. This is essentially an empty cabinet, finished and trimmed to be visually consistent with the switchboard sections

9 INTEROFFICE CALLS

9.1 Definition

An interoffice call originates with a line served by one central office but the called party is in another central office (in the same city, however, so this is still "local" operation).

This discussion will revolve around the concept of the "A" and "B" switchboards in a central office. As in the earlier mention of the roles of these two switchboards, I will predicate the discussion on the "basic" plan.

9.2 A map of the battle zone

We can follow the action on figure 21.

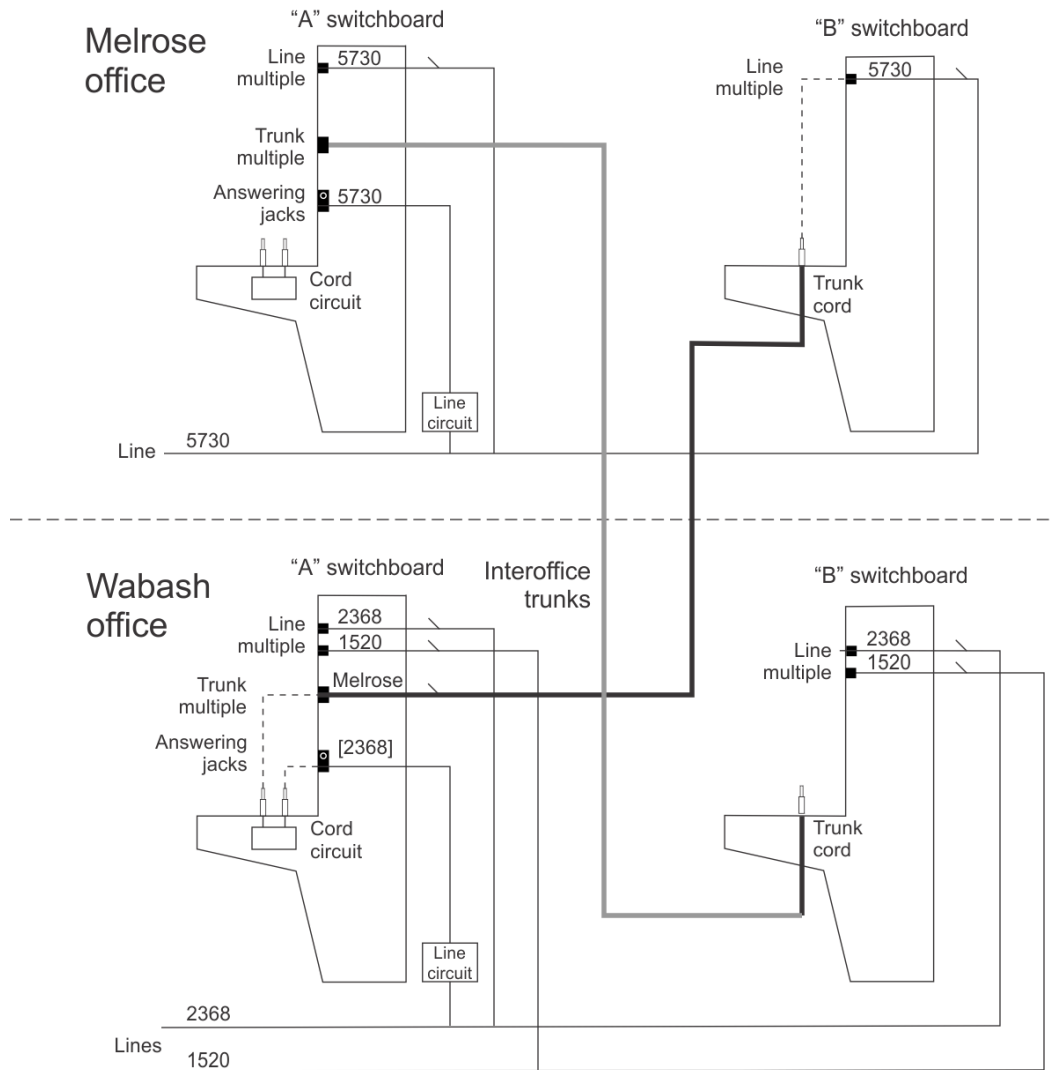

Figure 21. Interoffice traffic

We see here the Wabash office and the Melrose office. At each office we see a position of the "A" switchboard and a position of the "B" switchboard. The job of the "B" switchboard here is to "complete" calls that originated at other central offices.

We note that at each office the lines are not only connected to jacks on the line multiple at the "A" switchboard positions but also to a similar line multiple at the "B" switchboard positions. However, there are no answering jacks at the "B" switchboard positions (they would play no role in its job description).

We note that the interoffice trunks do not terminate in jacks at the destination "B" board. Rather, each one terminates in a cord (the cord circuits here have only one cord). This will be discussed further shortly.

For completeness I also show an interoffice trunk from the "A" switchboard at Melrose to the "B" switchboard at Wabash, used for Melrose-Wabash calls. But I will use a Wabash-Melrose call in the discussions.

9.3 Basic operation

The basic concept of operation is that when the calling party (we assume in the Wabash office, number Wabash 2368) lifts the receiver, the lamp on that line's answering jack lights (in what we will now recognize as being the "A" switchboard). The caller gives the number, including the name of the called party's central office ("Melrose 5730, please").

The "A" operator then extends the call by way of a *trunk circuit* (often called just a *trunk*) to the Melrose central office. At the Melrose office, a "B" operator accepts the call and delivers it to line 5730 there.

But there are several schemes of how this works (which is why I did not give more details in that basic description).

Two schemes have been important over this history of manual telephone switching:

- Call wire (or call circuit) operation
- Straightforward operation

We will cover each of them in a separate section, but first we will look into the construction of a "B" switchboard (which does not vary a lot between the two schemes of operation).

9.4 Basic construction of a "B" switchboard.

Figure 22 shows a typical "B" switchboard (yes quite an old one, but it essentially represents what came to be the "usual" design).

Before we examine it, let me speak of some "traffic" matters.

An "A" board operator can typically handle the traffic that can be handled by about 17 cord circuits (the "normal" complement of cord circuits, in fact).

A "B" board operator can handle the traffic coming in over maybe 45 to 50 trunks. (Her handling of a call takes less time than the "A" switchboard operator's handling of the call.)

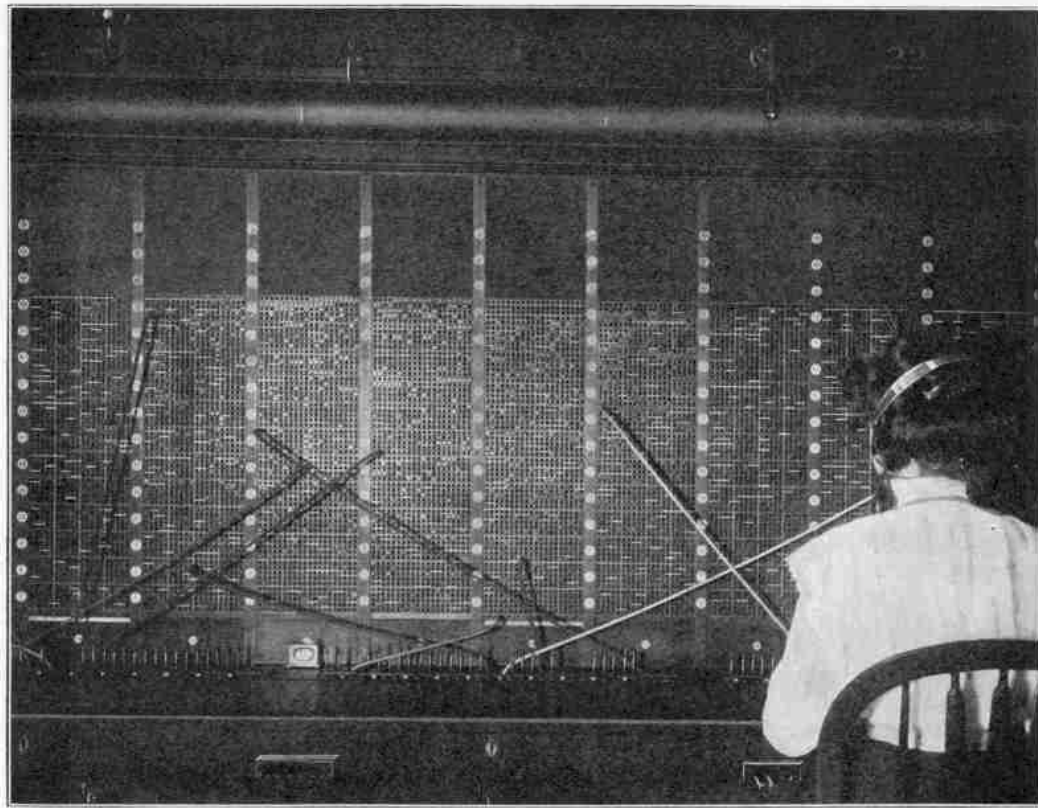

Figure 22. Typical "B" switchboard

Why do the incoming interoffice trunks terminate in cords rather than jacks at the "B" switchboard? Cord circuits are a common resource, and during heavy traffic times are, on the average, in use a large fraction of the time. Trunks between central offices are also a common resource, and during heavy traffic times are, on the average, in use a large fraction of the time.

Note the parallelism above between cord circuits and trunks.

It would thus be silly to have perhaps 45 trunks arriving at a certain "B" switchboard position on "trunk answering jacks" and to then have 45 cord circuits to handle the calls coming in over them.

So, at the "B" board, the trunk has its own cord circuit. That is, each trunk that comes to a position ends up on its own single cord (which works much like the front cord of an "A" switchboard cord circuit).

As the discussion above suggests, a "B" board position may have from 45 to 50 incoming trunks and thus the corresponding number of cord circuits.

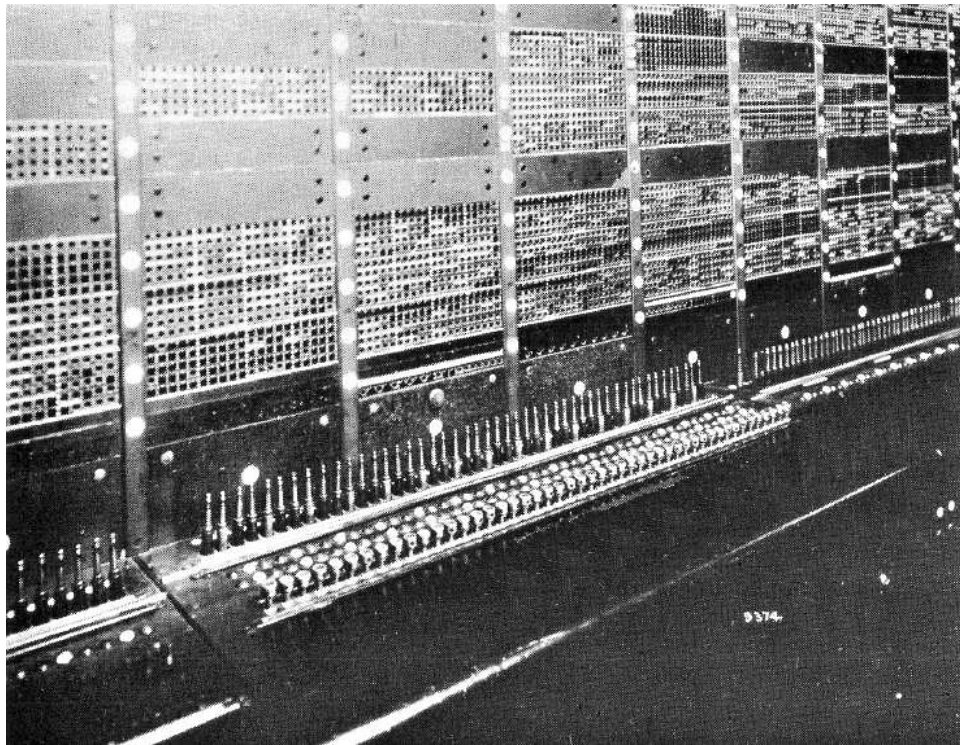

Figure 23. "B" switchboard showing trunk cords

Figure 23 gives us a better view of this cord arrangement.

This position we see in its entirety has 48 trunk cords (a common complement). (The photo is actually of a board for a special situation, so the jack field may not be set up as we might expect.)

The jack field of a "B" switchboard, for the most part, only has line multiple jacks (to which the incoming calls are completed).

Each trunk cord circuit takes up a little less width on the key/cord shelf than a cord circuit on an "A" switchboard, but there are many more cords. Thus a "B" switchboard position is wider than an "A" switchboard position.

In fact, "B" switchboards are typically made in sections of two positions. Often the section is 8 panels wide; typical "A" switchboard sections have 3 positions but are also 8 panels wide). The panels are of uniform width for both kinds of board.

So the "B" switchboard positions are about 1.5 times as wide as a typical "A" switchboard position. So "B" switchboard operators have a lot more "shoulder room" than "A" switchboard operators. More importantly, this makes room for the much larger number of cord circuits on a B board position. (The cord circuits are, however, a little narrower than in A boards.)

In figure 22, the “multiple repeat” is 7 panels. The board we see is at this point set up with 12 blocks (100 jacks each) per panel, for a total capacity of 8400 lines. As we can see from the extra number plates, the ultimate capacity of the design is 15 blocks per panel, for a total capacity of 10,500 lines. This design uses the smaller (109/309 type) plug.

The board seen in figure 23 also seemingly has a multiple repeat of 7 panels.

9.5 Call wire operation

Call circuit operation (sometimes called “call wire operation”) was, in the Bell Telephone System, the earliest scheme used for interoffice calling in major metropolitan areas.

Assume our city has five central offices, Wabash, Melrose, Maple, Jefferson, and Lakeside. Imagine that we are at the Wabash office. Then the trunk jack area of the “A” switchboard jack field has a number of trunks to each of Melrose, Maple, Jefferson, and Lakeside. Each trunk in the group to a particular office has a number (relative to that group).

These trunk jacks repeat (just like the line jacks in the multiple) so every operator can reach any trunk jack.³⁰ In fact, for this reason, the set of trunk jacks is often called the “trunk multiple”. (Then, to be scrupulous, the multiple with the line jacks is called the “line multiple”.)

The “A” operator answers a new call with a front cord in the usual way, and asks, “Number, please”. The caller says, “Melrose 5730, please”.

The “A” operator has on her key shelf a panel of non-locking push keys, each of which connects the operator’s telephone set to what we can think of as an “intercom” circuit to an operator at one of the other central offices. These are in fact called *call circuits* or, more colloquially, *call wires*.³¹ (We can see the call wire keys nicely in figure 4, to the left of all the cord circuits at each position.)

The “A” operator pushes the call wire key for the Melrose office, which means that her telephone is connected to the operator’s telephone set of a certain position at the East “B” switchboard. This is

³⁰ Maybe not exactly, but this will serve our purpose for now.

³¹ These should not be confused with *order wires*, which are “intercom” circuits, for example, between test boards, used by technicians in coordinating test work.

the position at which all the trunks from Wabash arrive, each on a cord (and maybe some trunks from other offices as well).

Note that this circuit to Melrose is also accessible to other A operators at Wabash, but also to A operators at, say, Maple, Jefferson, and Lakeside.

The "A" operator at Wabash waits until she hears that there is no other conversation with this East "B" operator (since the call wire is sort of a multistation intercom circuit), and then says, "Wabash 5730".

That sounds surprising—shouldn't it be "Melrose 5730", the full identity of the wanted line?

No. The Melrose "B" operator doesn't need to learn that the desired line for this nascent call will be in the Melrose office. Of course it is; she only handles calls to Melrose numbers.

But what she needs to know (we'll see why in just a minute) is from what office the call will be coming. That is of course Wabash, which she learns from the pronouncement of the "A" operator over the call wire.

She then looks at her cords bringing, to her position, trunks from Wabash, chooses an idle one (let's say it is number 15) (idle trunks' cords will be "at rest") and says over the call wire to the "A" operator at Wabash, "15".

At the Wabash office the "A" operator lets go of the Melrose call wire key and plugs the front cord of the cord circuit she used to answer the call into trunk jack 15 in the Melrose group. This sends a "seizure" signal forward over the trunk to the "B" board end. That lights an *assignment* lamp on the cord circuit at the Melrose "B" switchboard position.

The "B" operator takes up that trunk cord and with its plug makes a busy test in the usual way on line multiple jack 5730. If the line is not busy, she plugs that trunk cord into the jack and machine ringing commences.

The "B" operator has no further duties with regard to the call until the "A" operator disconnects from the trunk when the conversation is over. She for example is not concerned with when the called subscriber answers or later may hang up—those matters are in the purview of the originating "A" board operator.

When the called subscriber answers, the "B" board cord circuit sends a "supervisory" signal back over the trunk,³² which ultimately results in extinguishing the front cord supervisory lamp at the "A" board.

The "supervision" of the call is now, just as the intraoffice call case, wholly in the hands of the "A" operator. If the called party hangs up, the supervisory signal sent back over the trunk is returned to the "idle" state, which results in the lighting of the front cord supervisory lamp at the "A" board, telling the "A" operator that the calling party has hung up (just as if this were an intraoffice call).

Let's assume that the calling party also hangs up promptly. The "A" operator sees both supervisor lamps lit and pulls down both cords of the cord circuit. When the front cord leaves the trunk jack, the trunk circuit removes the seizure signal. This lights a *disconnect* lamp associated with that trunk cord at the Melrose "B" position. The "B" operator pulls the trunk cord out of the called party line jack.

Going back to an earlier point in the scenario, If the "B" operator finds that the wanted line is busy, she plugs the cord into one of a number of *busy jacks*. This sends busy tone (interrupted) back over the trunk, and also applies the supervisory signal intermittently in synchronism with the busy tone cadence.

The latter causes the front cord supervisory lamp at the "A" office to flash, advising the "A" operator that the line was busy. She need not announce that to the calling subscriber, however, who hears the audible busy tone directly. The operator will also hear the busy tone if she is still "on" that cord circuit.

However, she may have already moved on to handle another call by the time that happens. But she can tell that the called line on this first call is busy from the flashing of the supervisory lamp.

9.6 Straightforward operation

In this scheme, introduced in about 1915, the physical organization of the "B" switchboard is essentially as described above.

Again we will assume that there are Wabash, Melrose, Maple, Jefferson, and Lakeside central offices, and that we are at the Wabash office. As before, the trunk area of the jack field has a number of trunks to each of the Melrose, Maple, Jefferson, and Lakeside offices.

³² Often done by reversing the polarity of the voltage sent, by the terminating office, over the trunk to the originating office.

An "A" operator at Wabash answers a new call with a front cord in the usual way, and asks, "Number, please". The caller says, "Melrose 5730".

The "A" operator then considers in the trunk area of the jack field the set of trunks to the East central office. She looks for one of them that is idle. In the very earliest form of this scheme, she does by using the classical busy test procedure (with the tip of the front cord), "scanning" the trunk jacks until one is found that does not "test busy".

The process of choosing an ideal trunk from the group to the destination office by way of the traditional busy test is of course rather tedious. Various clever schemes were quickly devised to facilitate the process, but it was still not handsome.

A worthwhile later development was to provide each trunk jack with a "busy indicator", initially an electromagnetic unit where the magnet moved a small shutter, resulting in a small window showing white rather than black for a busy trunk. We see this in Figure 24.

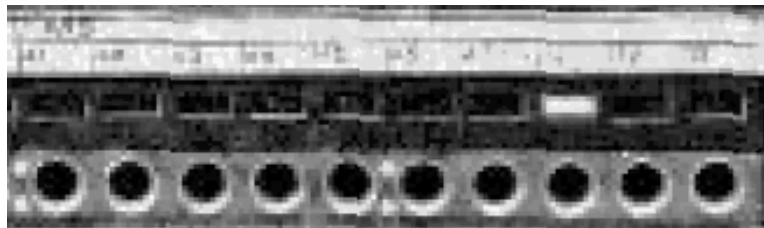

Figure 24. Trunk busy indicator

This of course took additional vertical space in the trunk multiple. A later development used lamps mounted behind the designation strips (they lit little translucent spots in the paper strips). Thus, no extra space was required for the busy indication. Usually only one lamp was lit in a group (an arbitrary one of the currently idle trunks, which is "next up")

In any case, the operator puts the front cord plug into the chosen idle trunk jack.

On the trunk circuit itself, a DC voltage is sent from the "B" switchboard, but when the trunk is idle, there is no DC path between the conductors at the "A" end, so no current flows.

But when the "A" operator plugs a cord into the trunk jack, the sleeve current operates a relay in the trunk circuit that closes a DC path (often through a winding of a coupling transformer) between the trunk conductors, and current now flows.

That flow is detected by a relay in the trunk circuit at the "B" office, and lights the *assignment* lamp associated with the cord. The "B" operator presses a key associated with the cord (we see those in Figure 23, as that board is set up for this mode), which connects her telephone set to that trunk/cord, and she probably takes the cord to hand.

Two quick "pips" of tone³³ are sent over the trunk to the "A" operator, telling her that the "B" operator is on the trunk. (Thus the "B" operator need not say "hello", or "ready" or "go ahead" or anything.) The "A" operator says over the trunk to the "B" operator just the line number of the wanted line (perhaps "5730").

The rest of the operation is essentially as before.

In a later development, when the trunk is "seized" by the "A" operator, the "B" operator's telephone set is automatically connected to that trunk (assuming it isn't at the time attached to another trunk). This avoids the need for the "B" operator to push the answering key for the trunk. Then the "B" operator is alerted by the order tone (also of course a prompt to the "A" operator) that she is presumably about to receive an "order".

9.7 The trunk multiple at the "A" board

In general, at the "A" board, each trunk appears before several operators, in a scheme comparable to that for line jacks. For this reason, the array of trunk jacks is often called the *trunk multiple*.

10 NO MULTIPLE AND PARTIAL MULTIPLE "A" BOARDS

10.1 No multiple "A" boards

In a large city, three things compete for the available vertical space on the face of the "A" switchboard:

- The answering jack area.
- The trunk multiple, which would need to have many jacks because of the large number of other central offices and the need for each position to have access to a substantial group of trunks to each.
- The line multiple, which would need to have many jacks because of the large number of lines served by the office.

³³ This is actually called "order tone" or, colloquially, "zip tone", since we might describe its sound as "zip-zip".

And even without the matter of competition for vertical space, the cost of the multiple in the "A" switchboard, with literally many hundreds of thousands of jacks and three times that many connections (typically hand soldered)³⁴, is substantial.

One way to relieve this "squeeze" for space, and to avert the cost of the line multiple at the "A" switchboard, is to have the intraoffice calls completed by the local "B" switchboard (just like incoming calls from another office). Then the "A" switchboard would not need to have any line multiple at all.

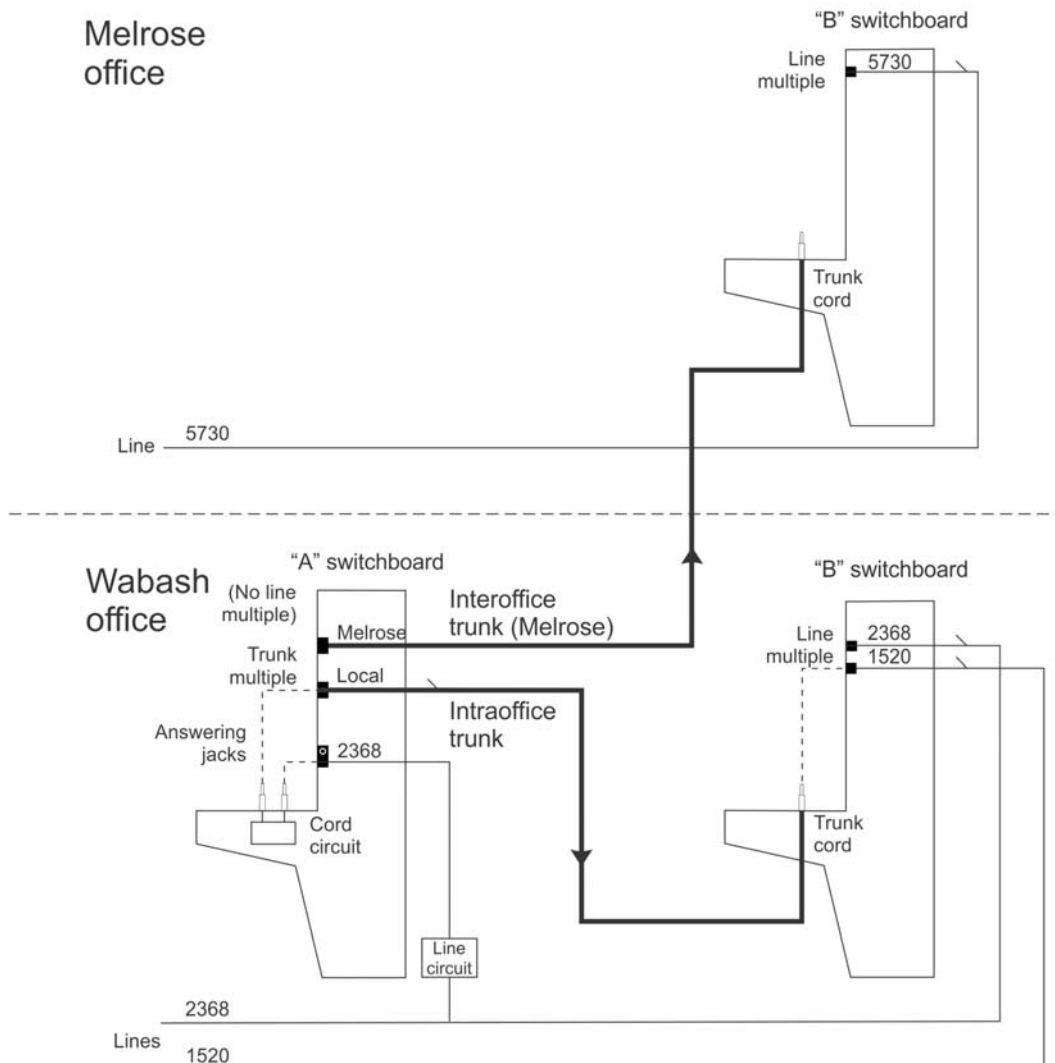

Figure 25. No-multiple "A" board operation

³⁴ No, these are not all done in the field. The multiple is made up at the factory. It is not easy to pack and transport. There must be enough cable at the end to reach to the intermediate distributing frame.

That is, if an "A" operator at Wabash picks up a call that is to another line in Wabash, she sends it over a trunk to a "B" switchboard position in the Wabash office (which is perhaps on the other side of the same room, or even on another floor).

Thus her trunk multiple will have trunks to Wabash (perhaps labeled "local"), as well as to all the other offices in town.

Figure 25 shows this arrangement.

(Of course the Melrose office has an "A" board, but it is not shown.)

While this adds to the amount of labor required for handling intraoffice calls, in some offices in large cities intraoffice calls are a small fraction of all calls (often only 25%, sometimes as little as 10%), so that penalty is not large.

10.2 Partial multiple "A" boards

A hybrid arrangement is used in some cases. Suppose that overall the situation favors a "no multiple" "A" board, but in fact there is a lot of intraoffice traffic to certain groups of lines (perhaps lines to the PBXs of a couple of big department stores in an area in which there are a lot of residents who are customers of those stores). Then it becomes desirable, from an operator labor standpoint, to have line jacks for just these lines on the "A" switchboard, an arrangement that is called the *partial multiple* arrangement.

Often there is an "area" of multiple jacks provided in the switchboard face layout to which, by cross-connections on a distributing frame, such groups of lines can be connected. These sets of jacks will not have contiguous numbers (as is the case on a normal "full" line multiple), so there are changeable provisions for labeling each jack with its number (all four digits).

Another aspect of such groups of lines is that the "store", which might have lines with numbers Wabash 2300 through Wabash 2348, will only "advertise" the number Wabash 2300 (called the "guide number" or "directory number"). But when an operator is handling a call to that number, if Wabash 2300 is busy, she will complete the call to the first line in the group that is not busy. That situation is indicated to the operator by a colored paint marking along that entire group of line jacks. (The jack mountings have a small groove at the bottom edge to facilitate the application of that marking.)

But to do this in the obvious way means that she will have to "scan" all the jack sleeves in the group to find one that does not test busy (does not give a click in her telephone set).

One scheme used to alleviate this is to consider these lines in subgroups of 5 or 10, with special relay circuitry such that, if all lines in such a group are busy, the jack sleeves of the first line in each subgroup carry not just a small DC voltage but a tone as well. Thus the operator can "scan" all the lines by merely touching the tip of her cord to the first jack in each subgroup, looking for a subgroup whose first line does not show the tone, then scanning the individual jacks of that subgroup until one is found that does not give the "click" indicating that the line is busy.

Another approach is to provide each of these line multiple jacks with a busy lamp, so the operator can, at a glance, choose an idle one.

We see that in Figure 26 (again an Automatic Electric board in Vancouver, B.C, ca. 1947)



Figure 26. Partial line multiple

10.3 About the names

Now, having seen what I call a "partial multiple" switchboard, I must report that in fact in many cases a system with a "no multiple" "A" board will be spoken of as a *partial multiple* system, the rationale being that the line multiple is provided across the "B" switchboard but not across the "A" switchboard, so it is "partial".

Pacific Telephone and Telegraph Company was a great exponent of not having a multiple on the "A" board, and in fact referred to an "A" board with a full multiple (as I first discussed) as a "combination 'A' and 'B' board" (since in their view only a "B" board should have a line multiple at all).

10.4 Size limit on the line multiple

Even knowing "standard" height of the jack face of a manual switchboard positions, we cannot directly determine the maximum number of jacks in the line multiple because there is another contender for the vertical space on the switchboard face, the *trunk multiple*. We will pursue that matter of overall capacity later (in section 13).

11 ANOTHER APPROACH—NO ANSWERING JACKS

11.1 Introduction

In the description above, each line, in addition to appearing at several places in the line multiple so that any operator could complete a call to it), also appeared at probably two places in a answering jack. These answering jack appearances had line lamps, which would light when a line was taken off-hook to make a call.

Thus a new call could handled by one of two operators in front of which the lines answering jacks appeared, and possibly by one or maybe even both of the operators at positions adjacent to those where the lines' answering jacks appeared.

Great attention was given to how to assign the various lines to answering jacks at various locations so as to attempt to equalize the call load over the cadre of operators on duty at any particular time of day. But that aspiration was imperfect.

11.2 A wholly different paradigm

When the No. 11 switchboard (introduced in 1924) was developed, a wholly new paradigm was introduced as the "norm" for that new switchboard. Here, in its basic form:

- There were no separate answering jacks.
- The jacks in the line multiple all had line lamps.

Thus, when a line came off-hook to make a new call, its line lamp lit at every appearance of that line on the line multiple. Thus, at least conceptually, any operator could take up such a new call.

11.3 Implications

There were a couple of problematical side effects of this, notably:

- a. There was now a risk than two or more operators would essentially-simultaneously answer such a "service request".
- b. Each jack in the line multiple took up twice as much space in the jackface, since each now had an associated line lamp. The result was that the maximum number of lines for which the switchboard could be equipped was dramatically reduced. (There was slight counterbalance to this, as there no longer needed to be answering jacks, but the net consumption of jackface real estate was still almost twice as much as with the classical system.) Perhaps the maximum capacity would be 3000 lines.
- c. There now needed to be four, rather than three, leads to each multiple jack (the added one being for the associated line lamp). These wires made the multiple cables fatter, and of course all had to be connected during the manufacture of the multiple "layers".

As to item a, improvements were eventually made to the cord circuits so that if two operators plugged into a line wanting service at almost the same time, only the "first cord in" actually made connection to the line.

11.4 No intermediate distributing frame needed

With no answering jacks, no intermediate distributing frame (IDF) (see Section 14.5) was needed, its purpose in the classical switchboard architecture being to assign an answering jack to each line.

The IDF is a bulky framework with a large floor space footprint, and connecting the cabling to the numerous terminal strips on it is very labor-intensive. Thus its elimination has very favorable economic implications.

11.5 A compromise form

As to item b, an alternate configuration was developed to increase the number of lines that could be accommodated (up to perhaps 6000). The concept is shown in figure 27.

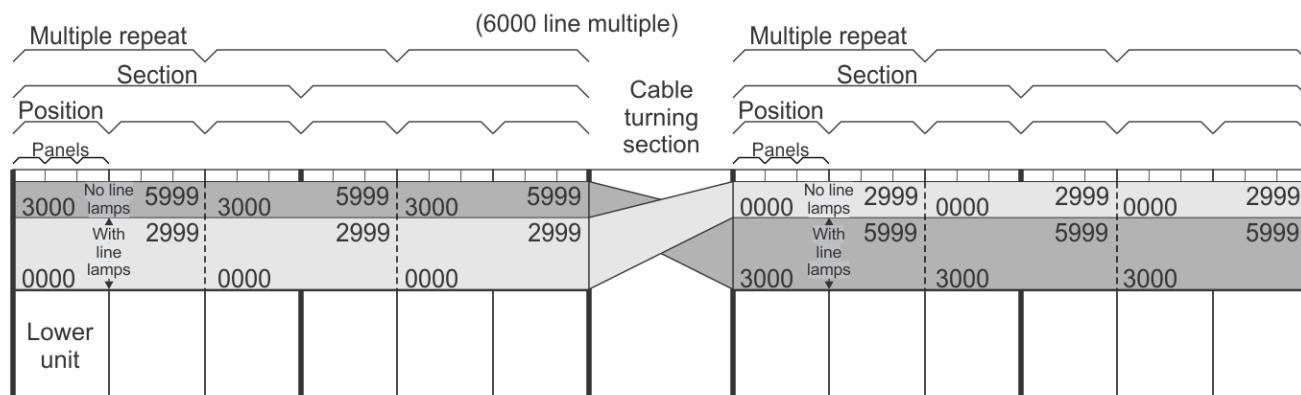

Figure 27. No. 12 switchboard—split multiple

This shows schematically the face layout of a hypothetical No. 12 switchboard handling 6000 lines (typically the maximum for this arrangement). The switchboard lineup (here 12 positions) is divided into two parts.

In this switchboard there are three panels per position, and the multiple repeat is six panels, exactly two positions.

I have for simplicity's sake ignored the "dummy section" issue discussed in section 8.18.

The line multiple is also divided into two equal parts. In the first part of the switchboard, the first half of the multiple (lines 0000-2999) has jacks with line lamps; the second half of the multiple (lines 3000-5999) has no line lamps. Thus the space required is only 1.5 times that required for the traditional configuration, versus the 2.0 times as much for the arrangement described just above.

In the second part of the switchboard, the situation is reversed. Now the second half of the multiple (lines 3000-5999) has line lamps, and is located at the bottom of the jackface. The first half of the multiple (lines 0000-2999) now has no line lamps, and is located at the top of the jackface. Again, the space required is only 1.5 times that required for the traditional configuration.

The physical reversal requires that the multiple cables be crossed amidships, which requires some distance. This happens in the *cable turning section* located between the two portions of the switchboard. As we saw earlier, this is essentially an empty cabinet, finished and trimmed to be visually consistent with the switchboard sections

With this arrangement, for a line in the range 0000-2999, any operator in the first portion of the switchboard can answer the call, and its line jack will be in the lower half of the jackface. For a line in the range 3000-5999, any operator in the second portion of the

switchboard can answer the call, and again its line jack will be in the lower half of the jackface.

12 THE PHYSICAL REALITIES

An "A" switchboard with 75 positions (not at all unusual) may have 28 multiple repeats. If the switchboard is equipped for 8000 lines, that is 224,000 jacks in the line multiple alone. There are 3 conductors for each line in the multiple, and so passing across the back of all the line multiple jacks, for the whole width of the switchboard, there will be 24,000 conductors.³⁵

Yes, that is (among other things) **very** heavy.

Figure 28 gives an appreciation of the enormity of the multiple cabling. This is at the Cortlandt central office in New York City (date unknown, but the photo is from an 1919 book).

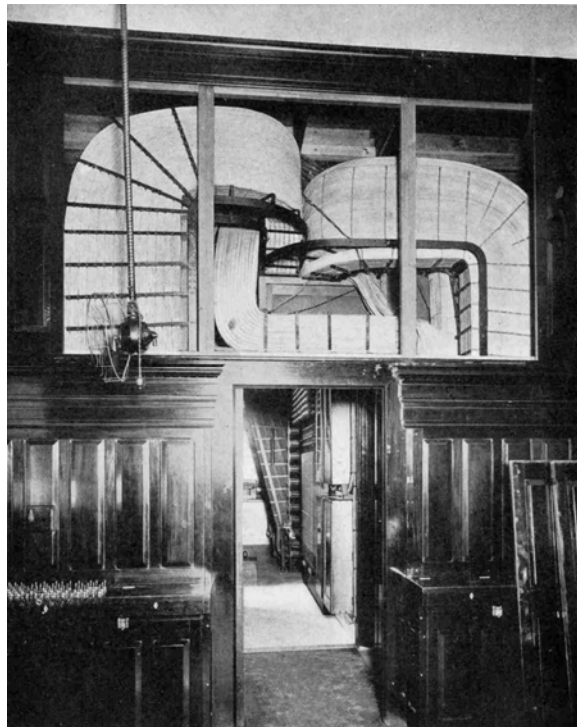

Figure 28. B and A switchboard multiple cabling

We are in front of the switchboard lineup between the "B" switchboard (on the left) and the "A" switchboard (on the right). In this installation, the cables enter the switchboards from overhead, at one end, into what is known as a "cable turning section".

³⁵ Meaning about 672,000 soldered connections.

Overhead on the left we see the cables of the line multiple for the "B" switchboard. The cables to the trunk cords are presumably hidden behind that.

In this office, the "A" board has a full line multiple. Overhead on the right, we see the cables to its line multiple; below that the cables to the answering jacks; and below that the cables to the trunk multiple.

At the other end, at the intermediate distributing frame, the conductors of these two sets of cables are collected in parallel. Each individual cable carries the conductors for one multiple jack strip—20 jacks, thus 60 conductors, plus at least 3 more (to be used to replace a conductor set that gets damaged).

If we go through the little doorway, we go into another large room and come to the front side of the *intermediate distributing frame*, as we see in figure 29.

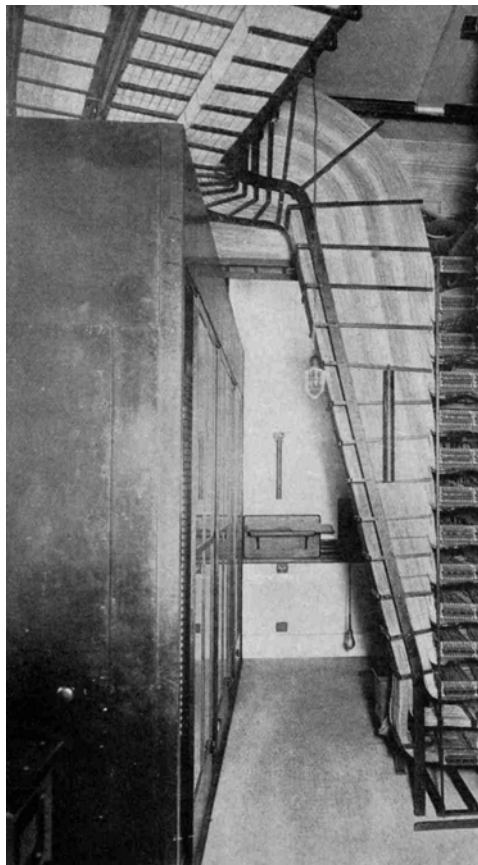

Figure 29. Multiple cables from the intermediate distributing frame

We can see the "cable pack" for the line multiple being built up from the various rows of terminal blocks on the distributing frame.

Among other things, in planning such an installation, care needs to be taken so that the individual multiple cables, when they arrive at the switchboard, are in the proper order, bottom-to-top and left-to-right, to

match the order of the multiple jacks. It is no fun if the whole pack has to take a "half twist", although in some situations that can't be avoided.

From this one can get some idea of the gigantic amount of very skilled labor involved in the planning and installation of such a switchboard system.

13 SWITCHBOARD "CAPACITY"

13.1 Introduction

I earlier dodged speaking of the "capacity" of various manual switchboard designs (in terms of the number of lines it might serve. But it is time to come to grips with that.

13.2 9600 line capacity

The No. 1 manual switchboard, using the smaller (e.g., 109-type) plug, and predicated on a "standard" division of the vertical space between the three classes of tenants mentioned above, was considered to have a capacity of 9600 lines (that is, 9600 jack strings in the line multiple). This was arranged with 1200 lines (12 jack "blocks") in each of the 8 panels that made up one multiple repeat (in the width of one switchboard section of three positions). As I mentioned before, this required the operator's "boarding house reach" to extend fully across the position to the left of her position and the one to the right. This was "workable", but "just barely".

13.3 10,500 line capacity

As discussed earlier, often in larger cities the "A" switchboards were set up on a "no-multiple" basis: there was a line multiple only on the "B" switchboard positions.

But on a "B" position there were no answering jacks and no trunk multiple, and so essentially all of the vertical "reach" of the operator could be devoted to line multiple. As a result, a "B" position could readily be arranged with a 10,500-line multiple. This was typically set up using only 7 panels, not 8, as the multiple repeat, each panel having up to 15 blocks of 100 lines each, 1500 lines per panel. This required less horizontal reach by the operator, a human factors improvement for the "B" operators. (But yes, a little greater vertical reach.)

Then, since we were no longer trying to squeeze as large a line multiple as possible into the "A" boards (and we still had only been generally able to attain a 9600 line capacity), the multiple repeat for the trunk multiple was cut back to 7 panels, also giving the "A" operators the benefit of not needing to make such a wide horizontal

reach. And in fact their vertical reach requirement was almost always significantly lower than for the “B” operators.

So, in fact, attainment of the famed “10,500 line” capacity of the smaller-jack switchboard was really a creature of the adoption of the *no multiple* or (or perhaps *partial multiple*) “A” board configuration.

13.4 Impact on telephone numbers

Of course, in an office with over 10,000 lines, a four-digit line number would not suffice. The plan was that the numbers would range from 0000 to 9999, and then from 10000 to 10499.³⁶ This did not really introduce any complication in the operation of the manual switching system itself. It did however introduce a big complication when “dial” operation was progressively introduced in a city.

There, elaborate arrangements were included to allow calls from “manual office” subscribers to “dial office” subscribers, and vice-versa, to be handled. A “dial office” subscriber calling a “manual office” subscriber might have to dial a telephone number including a four-digit station number or one including a five-digit station number.

And either a four-or five-digit station number needed to be sent over the trunk to the manual office “B” board (where the line number would be displayed on a panel to tell the “B” operator what number to plug the trunk cord into). That whole topic is beyond the scope of this article.

The reader interested in that matter will find it discussed in excruciating detail in the article, “The Panel Dial Telephone Switching System—Interoperation with Manual Switching Systems”, by the same author, probably available where you got this.

14 THE DISTRIBUTING FRAMES

14.1 Introduction

Important parts of the central office beyond the switchboards themselves are the *main distributing frame* (MDF) and the *intermediate distributing frame* (IDF).³⁷ There are structures on which, by way of semi-permanent wiring:

³⁶ Do not confuse the “ten-thousands digit” here with part of the later numbering system for dialed calls, like the “1” in MAin 1-2368, which was part of the central office code, not part of the line number.

³⁷ This is sometimes seen, inaccurately, as “distribution frame”.

- a particular subscriber's line, arriving at the central office on a certain pair of a certain cable, is given a telephone number by associating it with a particular string of jacks in the line multiple, and.
- a particular telephone number, as manifested by a particular string of jacks in the line multiple, is associated with a particular line circuit and answering jack(s).

In the traditional form (and almost all manual boards used this type), both of these structures consist of a large "jungle-gym-like" metal frame, on each side of which is an array of terminal blocks with numerous small metal terminals (or the equivalent). In the traditional design, on one side these are arranged in horizontal rows, and on the other side in vertical columns.

Figure 30 shows in block diagram form the roles played by these two distributing frames in a manual central office with A and B switchboards and a full line multiple on the A board.

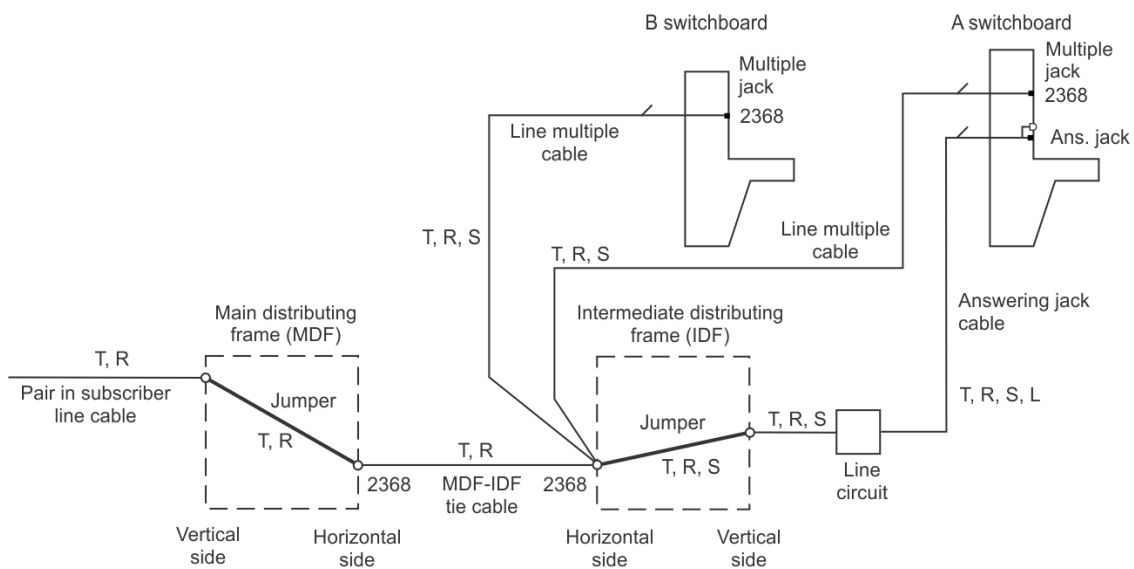

Figure 30. Distributing frames in a manual central office

The little diagonal lines extending up from the circuits to the jacks are the "multiple" symbol, reminding us that each of these circuits connects to "more of the same" (in this case, multiple jacks. That symbol on the answering jack circuit assumes the use of ancillary answering jacks.

The designations T, R, and S refer to the tip, ring, and sleeve leads. On the circuit to the answering jack(s), the "L" designation refers to the lamp lead.

14.2 The main distributing frame (MDF)

On the traditional MDF, all the pairs of all the incoming subscriber line cables are permanently connected to terminals on blocks on the vertical side, organized by cable number and pair number.³⁸ The pairs of the line multiple are permanently connected to terminals on blocks on the horizontal side, organized by telephone number.

Figure 31 illustrates a rather antique MDF (as befits our context), seen from the horizontal side. We see, through an open trapdoor, the arriving subscriber line cables (in a basement “cable vault”), destined for the vertical side of the frame. The cables from the horizontal side probably arrive at the right end of the frame (not visible here).

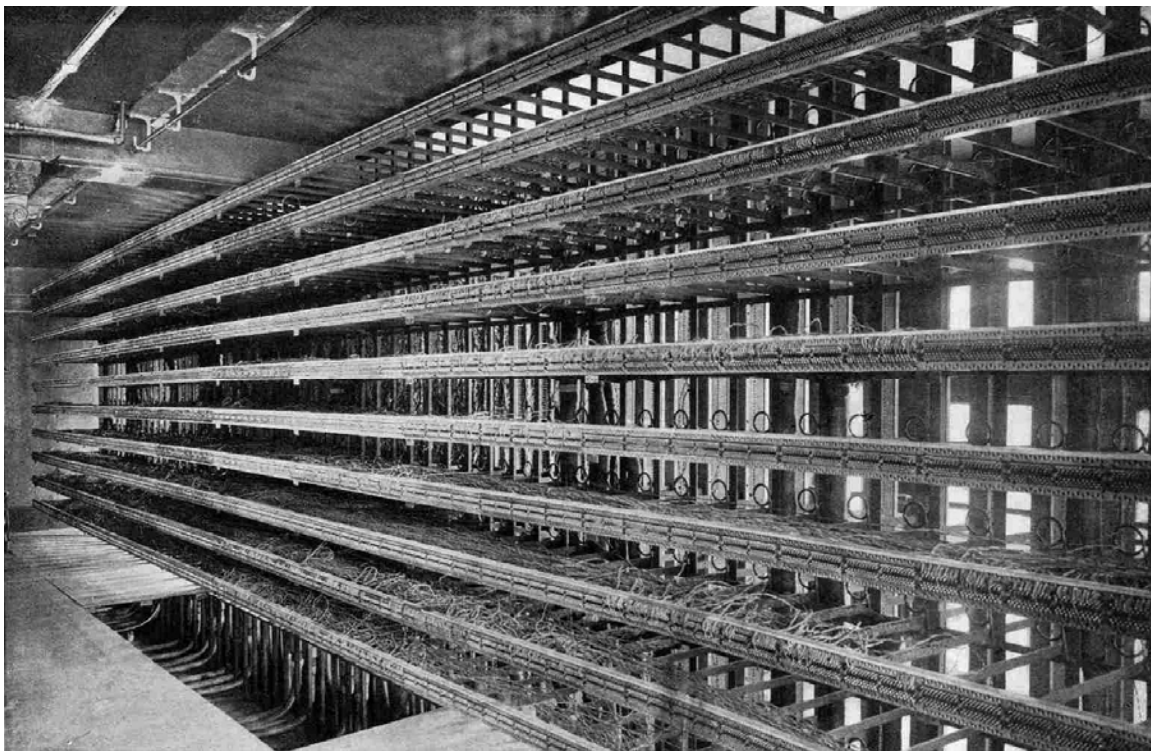

Figure 31. Main distributing frame (horizontal side)

14.3 Mezzanine distributing frames

In a large central office the MDF can be quite large. If the building layout does not allow it to be as “long” as is needed at the standard height (11’6” —central office equipment rooms generally had 15’ high

³⁸ Actually, these are not just terminal blocks but also “protector units” which incorporate, for each pair, components that protect against high voltages that might inappropriately appear on the conductors and from excessive currents that might somehow flow in the line conductors. The is of course a gigantic topic in its own right, but I will not pursue it further here.

ceilings), then the frame was made higher, and extended through a large opening in the ceiling/floor between floors in the building.

There would often be catwalks (“mezzanines”) at various heights from which the workers would operate. (In the more customary “single-floor” frames, rolling ladders³⁹ were used for access to the upper portions.)

14.4 Jumpers

When a subscriber arranges for new service, he is assigned a telephone number, and a certain pair in a certain cable is assigned to carry his line from the central office.

To effectuate this at the central office, technicians⁴⁰ run a length of two-conductor wire (of a very durable type) from:

- the two terminals on the vertical side on which the assigned cable pair is permanently terminated, to
- the two terminals on the horizontal side for the assigned telephone number, on which are permanently terminated the pair going to the string of multiple jacks for that number—two branches of that multiple pair, in fact, one going to the “A” switchboard line multiple and one to the “B” switchboard line multiple.

This length of wire is called a *jumper*.

The horizontal-side terminal blocks are supported by metal bars extending out from the central “spine” of the frame (best seen in the second horizontal row from the bottom in figure 31). These make a sort of very open shelf. There are also large diameter metal rings (“distributing rings”) behind each vertical column at the height of each such “shelf”.

Following from the horizontal side, the jumper is fed through a small hole in the wood base of the terminal block and is laid on the “shelf” made of the block supports of that horizontal row. It is led to the vertical-side column of the cable pair terminals to which it will be

³⁹ They were suspended and guided at the top by a trolley running in a channel-style rail suspended from the ceiling. These were also used for access to tall equipment racks (such as those carrying line and trunk circuits) and later, when automatic switching came into use, to access the switching equipment itself (which was generally in frames 11’6” tall).

⁴⁰ Known formally as “framemen” (this was of course before gender-neutral job titles), but colloquially as “frame monkeys” (a gender-neutral term, by the way).

connected. It is fed through the ring at that point and led up or down to reach that terminal.

The connections at each end were soldered. We see that being done in figure 32 (however, actually here on the vertical side of an IDF).

Note the natty attire of the switchman (IDF work was often done by switchmen rather than framemen, which is not to suggest that framemen were attired any less nattily)⁴¹.

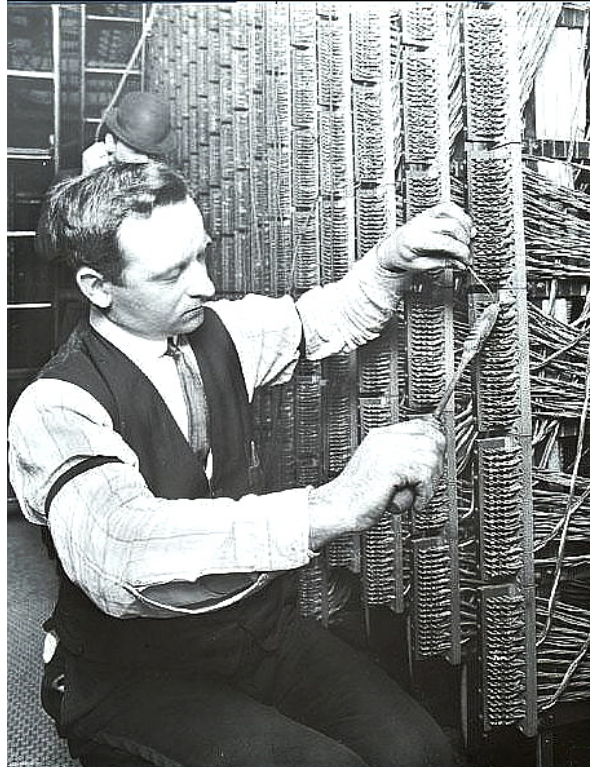

Figure 32. Soldering jumpers on the vertical side of the IDF

Note that this is not an electric soldering iron (or “soldering copper” to use the formal term. This type was heated in a small furnace fed by bottled gas (probably on the floor just out of sight in the picture).

Keep in mind that in a large central office there may be 10,000 or so of these jumpers in the MDF at any given time, so the job of placing new ones or removing obsolete ones in such a mass is not trivial. Normally, two framemen are needed to do the job (one on each side of

⁴¹ When automatic switching came into use, especially the “panel” system, which involved continuously rotating motor-driven rollers to move the switches, the four-in-hand tie was out (too much chance of its getting caught in the machinery) and a bow tie became *de rigueur* instead,

the frame) and they may use long poles with hooks at the end to manipulate the jumper.⁴²

14.5 The intermediate distributing frame (IDF)

Probably, that telephone number has already been (by virtue of its class) associated with a particular answering jack (and thus with a particular line circuit (the combination of line relay and cutoff relay used to recognize when the subscriber wished to make a call). This had been done at the MDF.

The IDF consists of a metal frame much like that of the MDF, on each side of which are sets of terminal blocks. As for the MDF, on one side, these are arranged in horizontal rows, and on the other side, in vertical columns.⁴³ As on the MDF, in the interior of the frame, the supports for the horizontal terminal blocks make up "open shelves". There are again metal distributing rings.

The blocks on the horizontal side carry terminals to which are connected all the pairs of the line multiple, brought there from the horizontal side of the MDF via *tie cables*. These terminals are organized by telephone number.

The blocks on the vertical side have terminals which are wired to line circuits (whose relays are in a nearby relay rack). From each line circuit, conductors go (on an essentially permanently-wired basis) to an answering jack and its associated lamp (maybe to two such, if there are ancillary answering jacks). These terminals are organized in terms of a numerical identifier for line circuits/answering jacks.

Each telephone number is assigned (on a semi-permanent basis, not normally changed each time the number is assigned to a subscriber) a particular answering jack (or two or three) and associated line circuit. This assignment is based on the expected calling traffic from a line of that class; lines of different classes are, for the most part, assigned telephone numbers from certain blocks to facilitate this process. The objective of this plan is to spread the calling traffic evenly over the

⁴² Sometimes, the telephone company may adopt the policy that, when service is discontinued or a telephone number changed, to save labor, the jumper is disconnected at both ends, but not "pulled" and discarded. Of course, after years of this practice, the jumper shelves become infested with literally tons of "dead jumpers", greatly increasing the labor to emplace new jumpers. "Pay me now or pay me later."

⁴³ Here these are normal terminal blocks, not "protector units", as in the case of the vertical side of the MDF, which makes the mechanical arrangements a little different..

operator positions, by giving each position a mix of answering jacks from the different line classes.

This assignment of an answering jack to each telephone number is effected at the IDF. Basically, a jumper is run from the terminal on the horizontal side for the telephone number of interest to a terminal on the vertical side leading to the assigned answering jack (by way of its line circuit).

15 MULTI-SWITCHBOARD OFFICES

Quite commonly, the area most economically served by a central office will embrace more lines (or telephone numbers) than can be handled by a single switchboard (again, the normal maximum capacity of the No. 1 common battery switchboard, under the partial multiple arrangement, was 10,500 lines/numbers). Thus we may have in the same building two (or even more) separate switchboards. These will have distinct "central office names" (perhaps Main and Cherry) for their telephone numbers. Calls from a subscriber with a "Main" number to one with a "Cherry" number, who perhaps lived next door⁴⁴, were handled on an interoffice basis from the Main "A" board through the Cherry "B" board.

In the single-switchboard case, the central office itself (in the sense of a building or building complex) might have been designated by a name such as "Washington Road", but more likely by the corresponding "central office name" ("Garfield"). In the multi-switchboard case, that might be a joint name, such as "Main-Cherry" or "Atlantic-Olympic".

Ordinarily, a multi-switchboard office had a consolidated main distributing frame.

16 CONCLUSION

There are of course innumerable other aspects and details of manual telephone switching, but these are beyond the scope of this article (and most of them beyond my ken as well). I have for example not spoken at all of how the local switchboard (often special parts of it) interoperates with the long distance network.

Then there is the gigantic and wholly fascinating matter of, when automatic ("dial") switching was progressively introduced in a certain city, how calls were handled from a manual office to a dial office, or vice-versa. But the reader who is really interested in that can find out

⁴⁴ Telephone numbers with one or the other of central office names were not ordinarily assigned by geographic sub-area.

about it from the article, "The Panel Dial Telephone Switching System—Interoperation with Manual Switching Systems", by the same author, probably available where you got this.

In any case, hopefully the reader has from this article gained an appreciation of the wondrous thing that was manual telephone switching. It made our modern world possible.

-#-

Appendix A

Multi-party lines

A.1 Introduction

In a multi-party line (known to the general public as a “party line”), a single pair of wires leads from the switchboard to two or more subscriber stations.⁴⁵ This of course has economic benefits through the sharing of the cost of the single pair of wires (and its portion of the equipment at the central office).

There were several different schemes of operation of multi-party lines, and two substantially-different principles of their operation at a switchboard, all with wonderful details and great cleverness of engineering and design.

In this appendix we will discuss concisely what was perhaps the most important multi-part line system in metropolitan areas, the two-party line, in its most-important implementation in manual switching systems.

The reader interested in more about this fascinating aspect of manual switchboard operation may wish to read the very detailed companion article, “Multi-party telephone lines”, or the smaller-scope article, “Ringing in multi-party telephone lines”, both by the same author, probably available where you got this.

A.2 Issues in multi-party line working

The entire sphere of multi-party lines is incredibly complex, with many issues, each of which have brought forth floods of ingenuity by inventors. Among the most important issues are:

- a. How does the central office signal (“ring”) the individual subscribers on the line?
- b. How does the central office know which subscriber is originating a call so that, if applicable, the call can be counted for billing purposes?
- c. How do we provide privacy for the various subscribers sharing a single line?

⁴⁵ The line may actually have separate pairs electrically in parallel, in different cables for a short distance as we near the neighborhood of the stations, for example if they are on separate streets.

In North America, almost completely, issue “c” has just been ignored: if one subscriber is talking on the line, any other subscriber, lifting their telephone handset, will hear the conversation.⁴⁶

Issue “b” is generally not dealt with in a “technical” way with manual switchboards.

I will deal here in some detail with a single, very-important approach to issue “a”, as practiced through manual switchboards.

A.3 In the Bell system

In the Bell Telephone System, in metropolitan areas, two types of multi-party line were common, the two party full-selective line and the four-party full-selective line.

“Full selective” means that a distinct electrical signal is sent for calls to each party, such that only the ringer at the called station rings. This is as contrasted to “semi-selective” systems, in which several ringers on the line ring for a call to any station, but distinctive ringing pattern are used so the subscribers can tell if the call is for them (“That’s my ring”). This is of course much less satisfactory to the subscribers than a full-selective scheme, which is why the Bell System tried to use those as much as possible.

In this appendix I will discuss what are perhaps the most common ways of implementing two- and four-party lines in a metropolitan manual switching system.

A.4 Two-party lines

16.1 Divided ringing

The most common system used to alert the two subscribers on a two-party line is called *divided ringing*, and this is the scheme I will discuss here. It is a *full-selective* system: when there is a call for one of the subscribers on the line, their telephone rings, and at the other subscriber’s station the telephone doesn’t ring.

A.4.1 Basic operation

Recall that, as discussed in the body of this article, in an individual line, the ringing voltage is applied between the ring and tip conducts of the line, and at the station, the ringer is connected (through a capacitor) from the ring to the tip.

⁴⁶ In Europe, this would be unthinkable, thus leading to more complex implementations of multi-party lines.

In a two-party line using divided ringing, at one station the ringer is connected (again through a capacitor) from the ring conductor of the line to (local) ground; at the other station, the ringer is connected (through a capacitor) from the tip conductor of the line to (local) ground. We see this in figure 33. which shows the arrangements at the "1st party" station and the "2nd party" station.

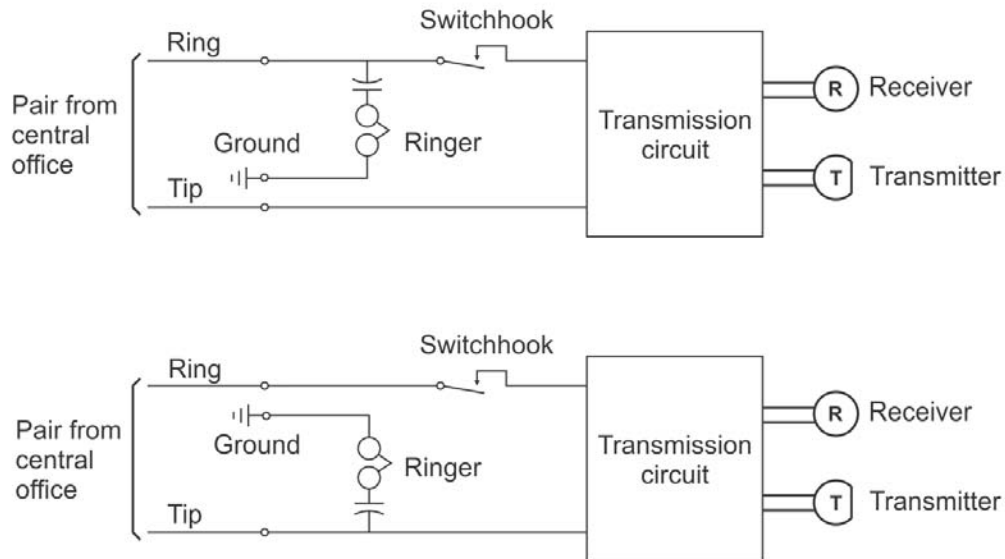

Figure 33. Divided ringing—1st and 2nd party stations

In technical discussions, the stations of the two parties are usually referred to as the *tip party* and *ring party* stations, of course based on which of the line conductors the ringer is connected to.

For a call to the ring party station, at the central office, ringing voltage ("against ground") is connected to the ring conductor of the line; the tip conductor is grounded.

For a call to the tip party station, at the central office, ringing voltage is connected to the tip conductor of the line; the ring conductor is grounded.

The result is that, for a call to a certain party, the ringer at that station receives the ringing voltage and rings. At the other station, the ringer is connected between two points that are both grounded (a line conductor and local ground), and thus receives no voltage, and does not ring.

A.5 Numbering plans

There are two basic concepts used for telephone numbering when multi-party lines are in the picture.

In one, the base telephone number indicates the line, while a suffix indicates the station. Thus, for the two parties on a certain line, for one the telephone number might be 1642-1, and for the other party 1642-2.

In the other scheme, the two parties have totally independent numbers, for example 2368 and 5569.

These two numbering schemes match with two different schemes of operation of the manual switchboard.

A.6 Jack-per-line operation

When the numbering plan uses a base number that indicates the line, with some type of suffix (often "1" vs. "2") indicating the party, normally the line appears on the switchboard line multiple in the usual way, on jacks that carry the base (line) number.

If divided ringing is used, the operator can then apply the proper one of the two ringing "signals", as indicated by the number suffix, perhaps by operating the ringing key on the cord circuit in one of two directions.

This is known as *jack per line* operation. It was not usually used for two-party lines in a metropolitan setting.

A.7 Jack-per-station operation

A.7.1 Introduction

When the numbering plan uses an independently-assigned number for each party (the most common arrangement for two-party lines in metropolitan areas), we normally have *jack per station* operation at a manual switchboard. Before I discuss it, let me give some pivotal background.

A.7.2 Comparison with individual line ringing

Recall that for an individual line (the premise of all discussion in the body of this article), I described the ringing voltage as being "applied between the ring and tip conductors". Not emphasized was the fact that one side of the ringing source is grounded (to local ground at the central office). Normally, it was this side of the ringing source that is connected to the tip conductor when a line is rung. So, looking at it in a different way that before, we recognize that when an individual line is rung, the ringing voltage (measured against ground) appears on the ring conductor, and the tip conductor is grounded.

This is exactly the situation we have on a two party line with divided ringing when the first ("ring") party is being rung.

Of course, for the ring party station on a two-party line, the ringer is connected from the ring conductor to ground, whereas for an individual line, the ringer is connected from the ring conductor to the tip conductor. But in either case, the ringer will ring when ringing voltage is placed on the line in the "normal" way.

A.7.3 And for the tip party

Now imagine that when there was a call for the second ("tip") party on the line, the central office applied ringing voltage in the "normal" way, but somehow the line conductors were reversed at the central office. The result of course would be that ringing voltage is applied to the tip conductor, with ground on the ring conductor. And as a consequence, the ringer at the tip party station rings (and the ringer at the ring party station does not).

A.7.4 At the manual switchboard

The discussions in sections A.7.2 and A.7.3 above illuminate the key to a very convenient way of providing for the proper ringing of the two parties at a manual switchboard. We see the basics of its implementation in figure 34.

The figure shows one two-party line. The ring party has telephone number 2490, while the tip party has number 1528. We see that the line proper (the "cable pair") is connected, through a jumper on the MDF, to line multiple jack string "2490" on the switchboard.

The line proper is also connected, through a separate MDF jumper, to line multiple jack string "1528", but in this case the two conductors of the jumper are reversed in their connection to the tip and ring terminals on the switchboard side ("telephone number side") of the MDF.

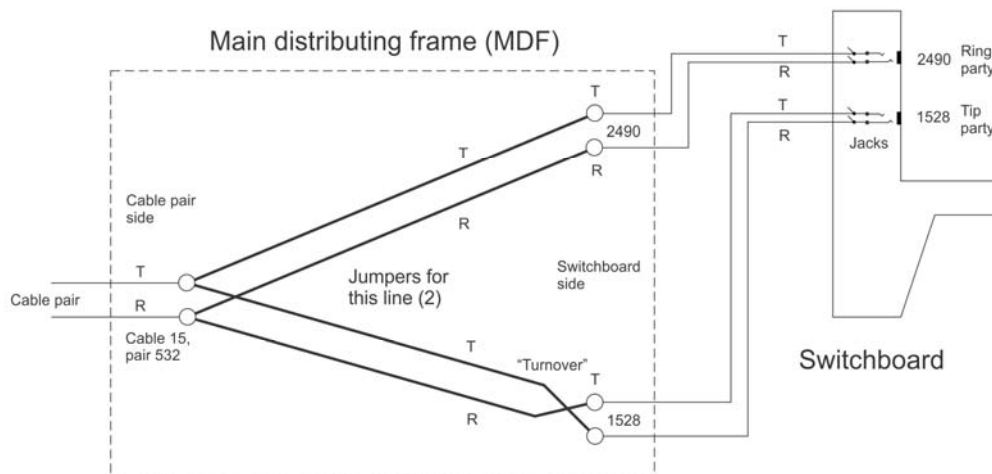

Figure 34. Jack-per-station operation

On a call to 2490, the operator plugs in the front cord of the cord circuit to the nearest "2490" jack and ringing begins. The electrical situation at the switchboard is identical to that for an individual line. We say that the ringing voltage is "applied between ring and tip". But as we saw earlier, one side of the ringing voltage is grounded, the side that is connected to the tip.

Thus we have (with respect to ground) ringing voltage on the ring, with the tip grounded. And so the ringer at the ring party ("2490") rings, while the ringer at the tip party ("1528") does not.

Now, on a call for 1528, the operator plugs in the front cord of the cord circuit to the nearest "1528" jack and ringing begins. As before, this means that ringing voltage is applied to the ring of the jack, and ground to the tip.

But, because of the "turnover" of the MDF jumper for this number, this means that ringing voltage is applied to the tip of the line itself, and ground to the ring. And so the ringer at the tip party ("1528") rings, while the ringer at the ring party ("2490") does not.

Thus we see that two-party divided ringing is provided for with absolutely no special circuitry at the switchboard.

This approach is called *jack per station* operation.

Although we don't show it in the figure, the line goes to a single string of answering jacks.

A.8 Four-party lines

A.8.1 Introduction

At one time, four-party lines (in the best case, with full-selective ringing), were also commonly offered by the Bell System in metropolitan areas. I will discuss what is the most common implementation (for the full-selective mode).

A.8.2 Four-party full-selective party line ringing

Here, there are four distinct ringing signals that can be sent on the line. The ringer at each station will only respond to one of them. These four signals are composed of two two-way choices:

- The ringing voltage can be applied (against ground to either the ring or tip conductor of the line, the other being grounded (just as in two-party divided ringing).
- The DC component of the ringing voltage can be either negative or positive.

In order that the station ringer can be connected so it can discriminate with regard to the second of these factors, there must either be a relay (in the earlier implementations) or a gas triode included in the station ringer circuitry of all stations on a four-party line of this type. (The details are beyond the scope of this article.)

A.8.3 Numbering plan

Most commonly in the context of manual switching in a metropolitan area, the four parties on a four-party line have telephone numbers with the same four-digit station number, augmented by a letter suffix which indicates which of the four parties that station is. These letters are usually drawn from the set W, R, J, and M.⁴⁷

Thus one station on a certain line might have the telephone number Wabash 2368-W, and another station on the same line would have the telephone number Wabash 2368-J

A.8.4 Jack per line operation

In the most common implementation of this scheme in a manual office, when a call arrives at the Wabash office for "2368-W" (meaning for Wabash 2368-W) the operator finds the jack "2368" on then line multiple and, after making a busy test and finding that the line is not busy, plugs the front cord of the cord circuit into that jack and then on the key shelf for that cord circuit, depresses one of four "pushbutton" ringing keys, labeled "W," "R", "J", "M" (in this case, the "W" key). This arranges for the proper one of the four electrical signals to be applied to the line (perhaps automatically, if the board provides machine ringing).

As mentioned earlier in the context of two-party line operation, this approach is called *jack per line* operation.

-#-

⁴⁷ There is, sadly, no fully-uniform plan for associating the four electrical conditions with those four letters.